

DEPARTMENT OF THE ARMY TECHNICAL MANUAL

**DIRECT AND GENERAL SUPPORT
MAINTENANCE MANUAL**

**ARMAMENT SUBSYSTEM,
HELICOPTER, 7.62 MILLIMETER
MACHINE GUN: HIGH RATE,
XM27E1 (1005-933-6242) (USED ON
OH-6A HELICOPTERS)**

**This copy is a reprint which includes current pages from Changes 1
through 3**

**HEADQUARTERS, DEPARTMENT OF THE ARMY
JULY 1969**

WARNING

Warning: Do not attempt to troubleshoot a loaded weapon. Be sure no ammunition is present in any subsystem component before energizing the system.

Warning: Clear the weapon before starting inspection. Point weapon in a safe direction and determine if live rounds are present. Check bore and chamber for obstructions; for example, a bullet in the bore or a ruptured cartridge case in the chamber.

Warning: Personnel operating vapor degreaser are cautioned not to breathe the vapor fume.

Warning: Be sure there is no ammunition in any subsystem component before operating the electric gun drive.

Warning: If a power sander is used, avoid breathing the fine fiberglass dust produced. This dust can cause serious skin and respiratory irritations. Wear protective clothing and use a mask.

Change }
No. 1 }

HEADQUARTERS
DEPARTMENT OF THE ARMY
WASHINGTON, D. C. 8 October 1970

DIRECT AND GENERAL SUPPORT MAINTENANCE MANUAL
ARMAMENT SUBSYSTEM, HELICOPTER,
7.62 MILLIMETER MACHINE GUN:
HIGH RATE, XM27E1
(1005-933-6242)
(USED ON OH-6A AND OH-58A HELICOPTERS)

TM 9-1005-298-34, 30 July 1969, is changed as follows:

Change the title to read: **DIRECT AND GENERAL SUPPORT MAINTENANCE MANUAL**
ARMAMENT SUBSYSTEM, HELICOPTER,
7.62 MILLIMETER MACHINE GUN:
HIGH RATE, XM27E1
(1005-933-6242)
(USED ON OH-6A AND OH-58A HELICOPTERS)

Page i:

* * * * *
*

CHAPTER IV. REPAIR OF RAM AIR DUCT ASSEMBLY

* * * * *
*

Page 1-2:

Delete figure 1-1, WE 15616A, and substitute figure 1-1, WE 67170, Components of Armament Subsystem XM27E1.

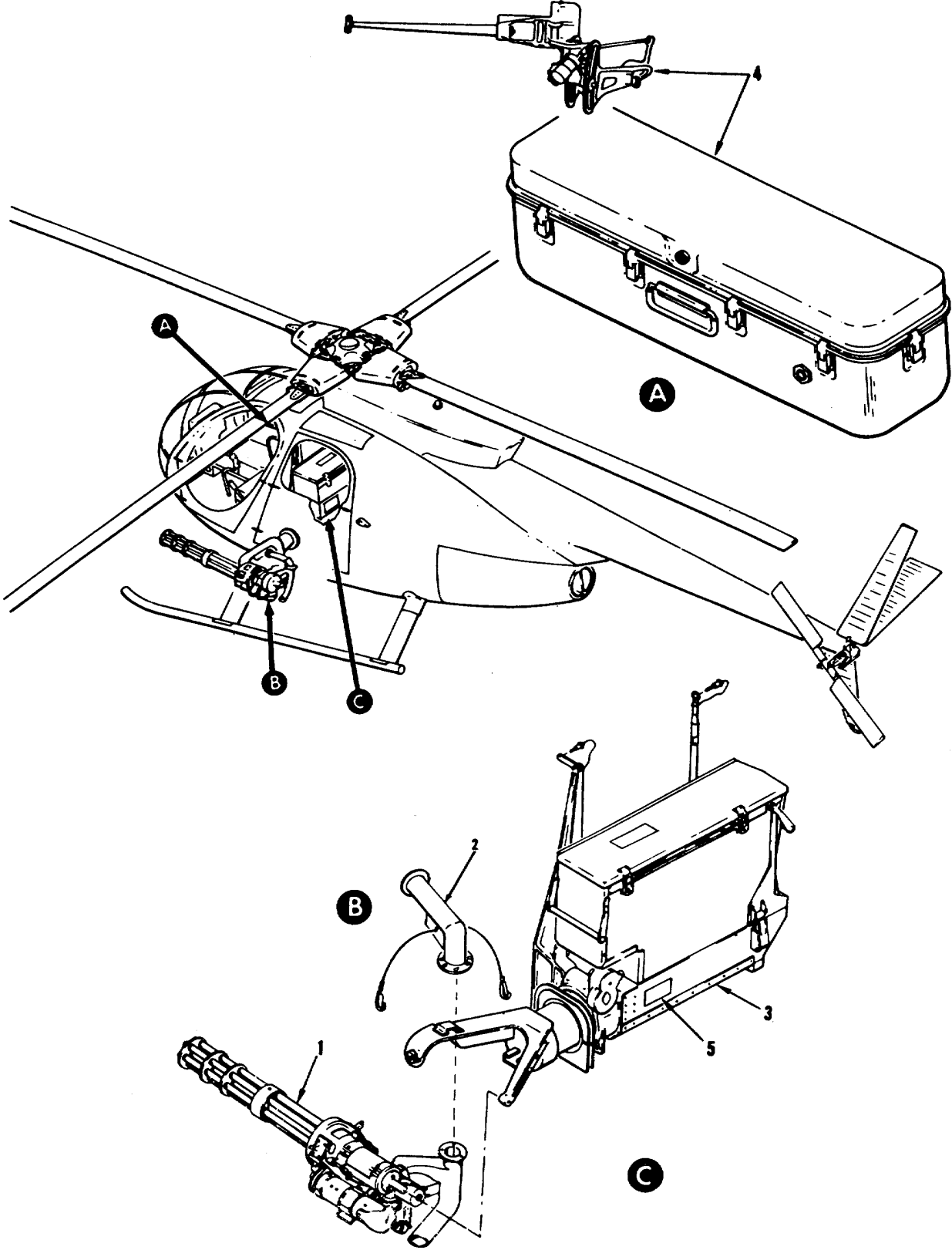

WE 671 70

Figure 1-1. (Superseded) Components of Armament Subsystem.

Page 3-5:

Delete figure 3-3, WE 61488, and substitute figure 3-3, WE 67172, Bolt Assembly-exploded view.

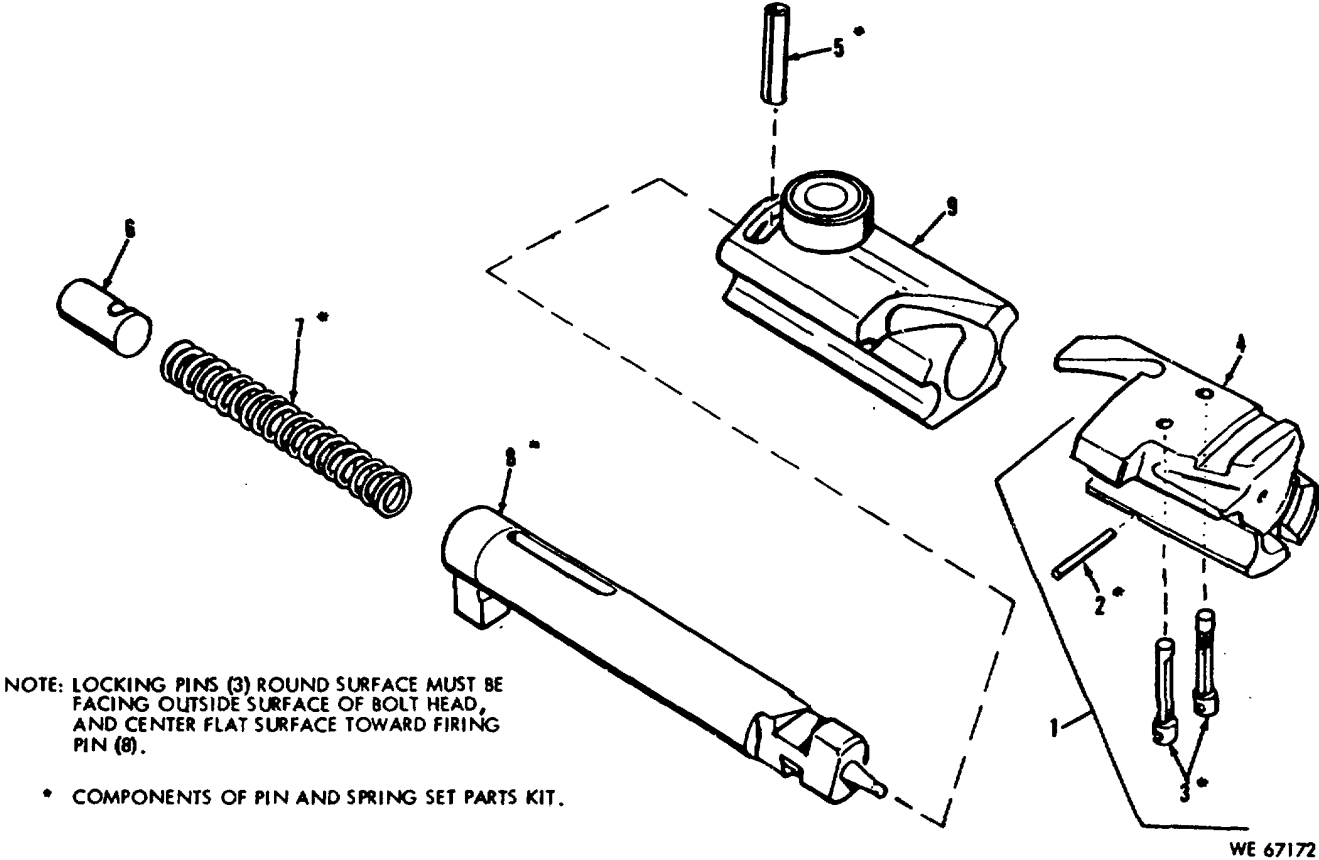

Figure 3-3. (Superseded) Bolt Assembly-exploded view.

Page 4-1:

**CHAPTER 4 (SUPERSEDED)
REPAIR OF RAM AIR DUCT ASSEMBLY**

4-1. Description

The ram air duct assembly is a metal air scoop, consisting of the ram air duct, three turnlock fasteners, retaining cable, two snap fasteners, and a rubber grommet.

4-2. Disassembly/ Assembly

See figure 4-1. Limit disassembly to removal of faulty parts such as fasteners, retaining cable, and rubber grommet.

4-3. Cleaning, Inspection, and Repair

- a. Cleaning. Refer to paragraph 2-9a and apply procedures used for cleaning mount assembly parts.
- b. Inspection. Check for damaged fasteners, frayed or broken retaining cable, and for torn or missing rubber grommet.
- c. Repair. Replace excessively worn, broken, or missing parts using standard shop procedures and tools.

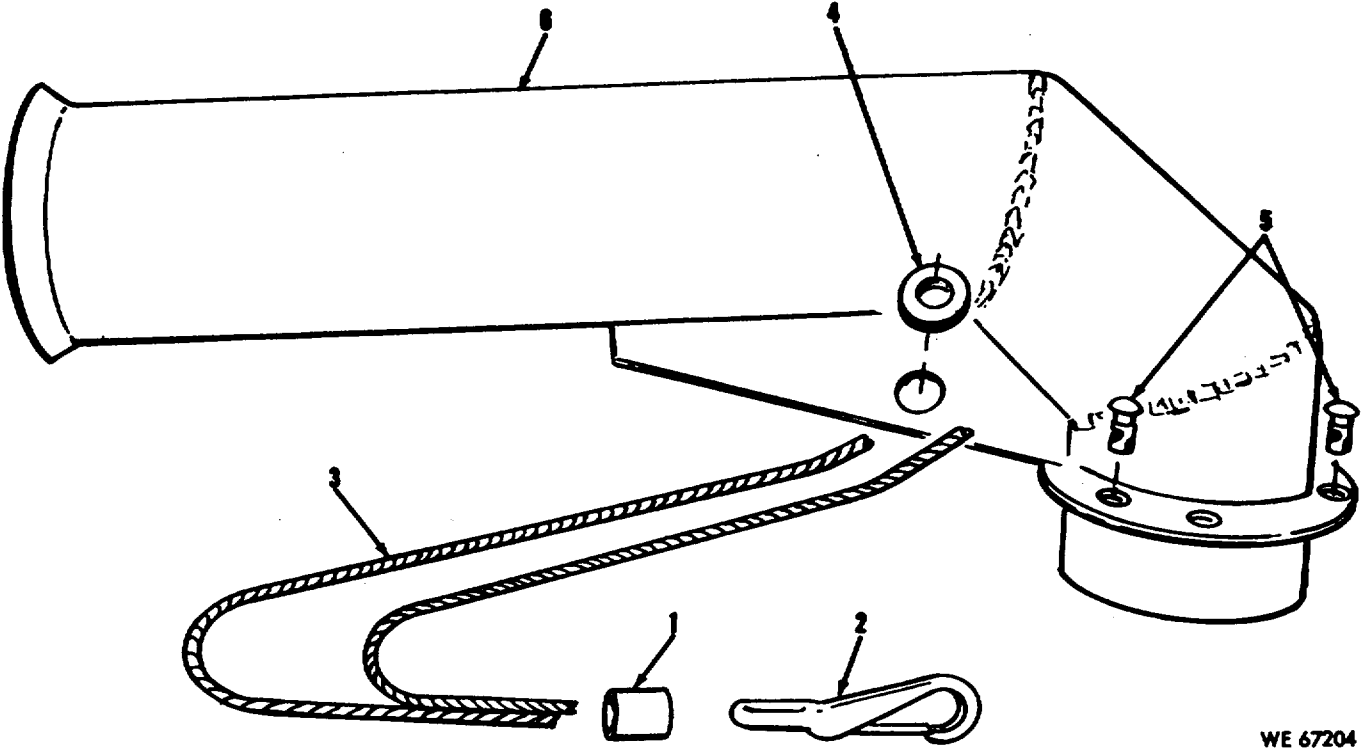

WE 67204

Figure 4-1. Ram air duct assembly-exploded view.

Page 5-16:

5-9. Cleaning, Inspection, and Repair

* * * * *

*

b. Inspection

* * * * *

*

(4) (Superseded) Check tube assembly parts including resilient mount (11, fig. 5-8), bolt ball (2), and camlock (9) for excessive wear or damage.

Delete figure 5-8, WE 15607, and substitute figure 5-8 WE 67241, tube assembly-partially exploded view.

Page 5-20:

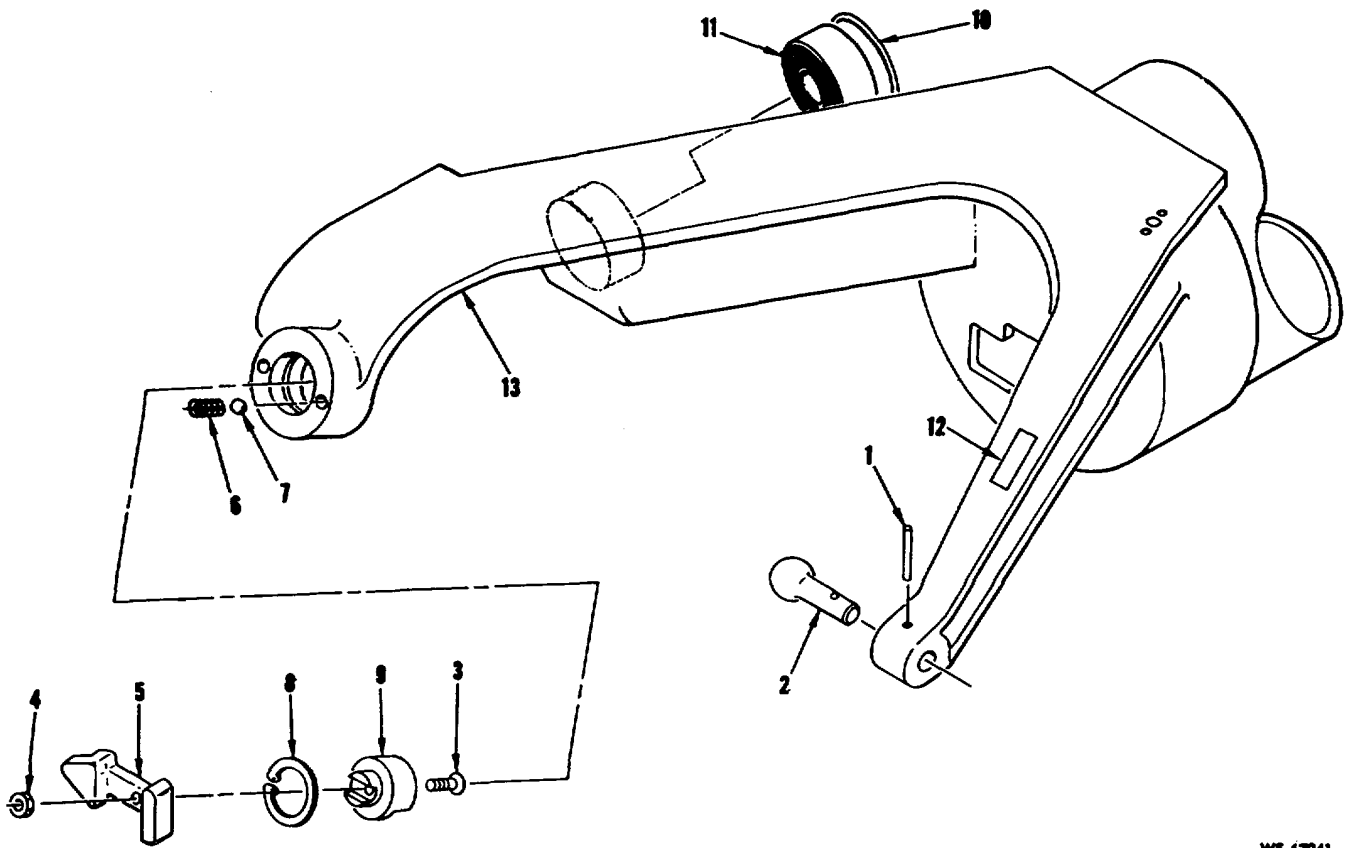

WE 67241

Figure 5-8 (Superseded) Tube Assembly-partially exploded view.

Delete the key for figure 5-8, WE 15607, and substitute the following key for figure 5-8, WE 67241:

- | | |
|---------------|----------------------|
| 1. Spring Pin | 8. Retaining Ring |
| 2. Bolt Bail | 9. Cam Lock |
| 3. Screw | 10. Retaining Ring |
| 4. Nut | 11. Mount, Resilient |
| 5. Knob, Lock | 12. Decal |
| 6. Spring | 13. Support Assembly |
| 7. Ball | |

Page 6-8:

Delete figure 6-4, WE 15615, and substitute figure 6-4 WE 52857, Reticle project assembly-partially exploded view.

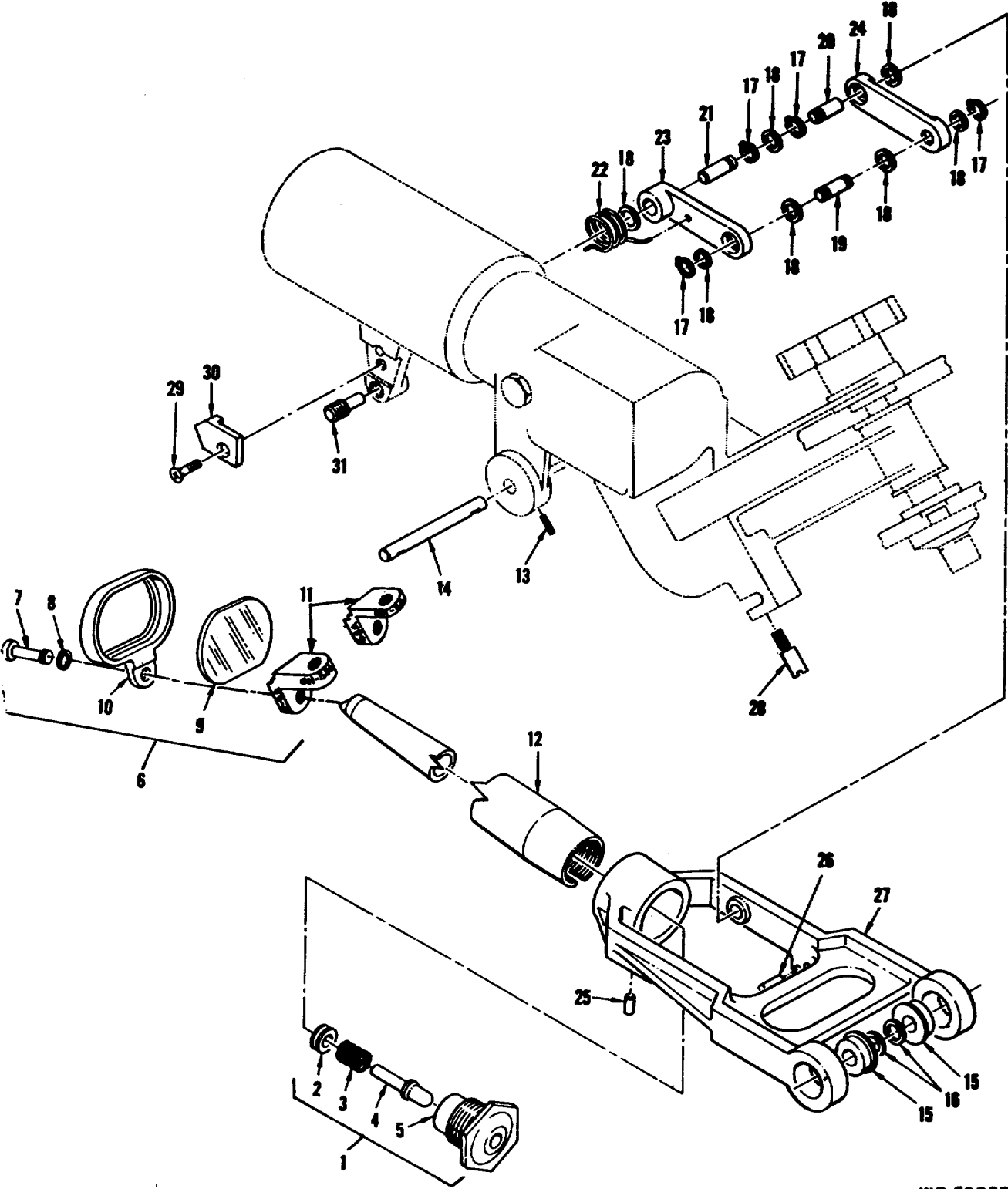

WE 52857

Figure 6-4 (Superseded) Reticle project assembly—partially exploded view.

Page 6-9:

Delete key for figure 6-4, and substitute the following:

- | | |
|--------------------------|-------------------|
| 1. Detent Assembly | 17. Retainer Ring |
| 2. Spring Retainer | 18. Washer |
| 3. Spring | 19. Shaft |
| 4. Plunger | 20. Shaft |
| 5. Body | 21. Shaft |
| 6. Beamsplitter Assembly | 22. Spring |
| 7. Screw | 23. Arm |
| 8. Washer | 24. Arm |
| 9. Lens | 25. Pin |
| 10. Retainer | 26. Spring Pin |
| 11. Adapter | 27. Arm |
| 12. Arm | 28. Screw |
| 13. Setscrew | 29. Screw |
| 14. Shaft | 30. Bracket |
| 15. Bearing | 31. Eccentric Pin |
| 16. Washer | |

By Order of the Secretary of the Army:

Official:

KENNETH G. WICKHAM,
*Major General, United States Army,
 The Adjutant General.*

W. C. WESTMORELAND,
*General, United States Army,
 Chief of Staff.*

Distribution

To be distributed in accordance with DA Form 12-31 (qty rqr block no. 129) Direct and General Support Maintenance requirements for Armament Subsystem XM27E1.

Changes in force: C 1, and C 2

Change
No. 2 }
}

HEADQUARTERS,
DEPARTMENT OF THE ARMY
Washington, D.C., 23 September 1971

**Direct and General Support
Maintenance Manual
ARMAMENT SUBSYSTEM,
HELICOPTER, 7.62 MILLIMETER
MACHINE GUN: HIGH RATE
XM27E1 (1005-933-6242) (USED ON
OH-6A AND OH-58A HELICOPTERS)**

TM 9-1005-298-34, 30 July 1969, is changed as follows:
Page 2-11. Paragraph 2-7e is superseded as follows:
e. *Threads/Screw Thread Inserts.*

(1) Repair of damaged threads shall be accomplished by use of a thread restorer, by chasing on a lathe, or by use of a tap of proper dimension.

(2) All screw thread inserts shall be installed in accordance with MS 33646. Remove notched tangs after installation. Damaged or defective inserts will be replaced. If hole is enlarged during removal of insert, an oversized insert should be used as replacement.

Page 3-5. Paragraph 3-5 is superseded as follows:

3-5. Disassembly/Assembly.

a. *Disassembly.* Refer to the numerical sequence in figures 3-4 and 3-4.1 and the following specific instructions for disassembly of the feeder and feeder housing assembly.

(1) Drive out pin (14, fig. 3-4) while plate (18) is still in place to support shaft (31).

(2) If pin (26) is badly bent and difficult to drive out, the following method of removal may be used.

(a) Position gear (27) so that it rests on a wooden block(s), with clearance for shaft (31).

(b) Strike shaft (31) sharply with soft-faced hammer to shear pin (26).

(c) Drive out pieces of pin (26) from gear (27), push rod guide (30), and shaft (31).

(3) When removing spring-loaded solenoid (45) assure that all matching parts are kept together for installation as a unit.

b. *Assembly.* Assembly of the feeder and feeder housing assembly is in reverse order of disassembly and the following instructions.

(1) After installation, face of identification plate (50, fig. 3-4) shall be coated with Lacquet Spec TT-L-58,

Type 1, Clear.

WARNING

Solenoid (45) consists of matched parts. Use only as a unit. Interchange of solenoid parts may result in a firing system malfunction.

(2) Install solenoid (45) using only matched parts.

(3) Install pin (29) with approximately 1/8 inch protruding.

NOTE

Pin (29) is for alignment of recess in inside diameter of gear (27) over push rod guide (30).

(4) Use 3/16 inch punch and align holes in gear (27), push rod guide (30), and shaft (31) so that a slot in guide is opposite point where punch enters gear.

(5) Hold gear (27) - push rod guide (30) - shaft (31) unit firmly, remove punch and install pin (26) through unit. Pin shall not protrude into slot of guide nor restrict gear tooth action.

NOTE

Stripper (23) is installed on shaft (31) so that slot in line with hole is in alignment with slot (para (4)) in push rod guide (30) having hole for pin (26).

(6) Install stripper (23) to shaft (31) with pin (22) entering from slot aligned hole in stripper. Pin shall be flush with surface of stripper.

(7) Press bearing (19) into guide plate (20) until flange of bearing is flush with surface of plate.

(8) Slide sprocket (21) onto shaft (31) so that alignment pin (24) of stripper (23) engages recess in

sprocket sleeve and install plate (18).

(9) Install pin (16) in sprocket (21) so that pin is flush with surface of sleeve.

NOTE

Prior to installation of instruction plate (9, fig. 3-4.1) adhesive on back shall be activated by use of acetone, methyl-ethyl-ketone, or methyl-isobutyl-ketone.

(10) Clean surface to receive instruction plate (9, fig. 3-4.1) so that it is free of oil, dirt, grease or other contaminants that could impair adhesion. Activate adhesive on back of plate and install on housing (12) using firm overall pressure.

(11) Install pins (8) so that approximately 3/8 inch protrudes on side toward instruction plate (9).

(12) After complete assembly of feeder perform the following checks and tests.

(a) Rotate sprocket (21, fig. 3-4) and shaft (31) to check for smooth operation.

(b) Check sprocket (21) and gear (27) to assure that there is no end play on shaft (31).

(c) Slide a round of ammunition through each opening (slot) in sprocket (21) and observe that there is no catching or binding.

(d) Check that clearing solenoid (45) is operating smoothly.¹

NOTE

Nose guide 11686381 (7, fig. 3-4), issued as part of a feeder, is replaced for XM27E1 only at assembly by nose guide 11697451, issued as part of gun assembly. Refer to TM 9-1005-298-12.

Pages 3-6, 3-7, and 3-8. Figure 3-4 is superseded as follows:

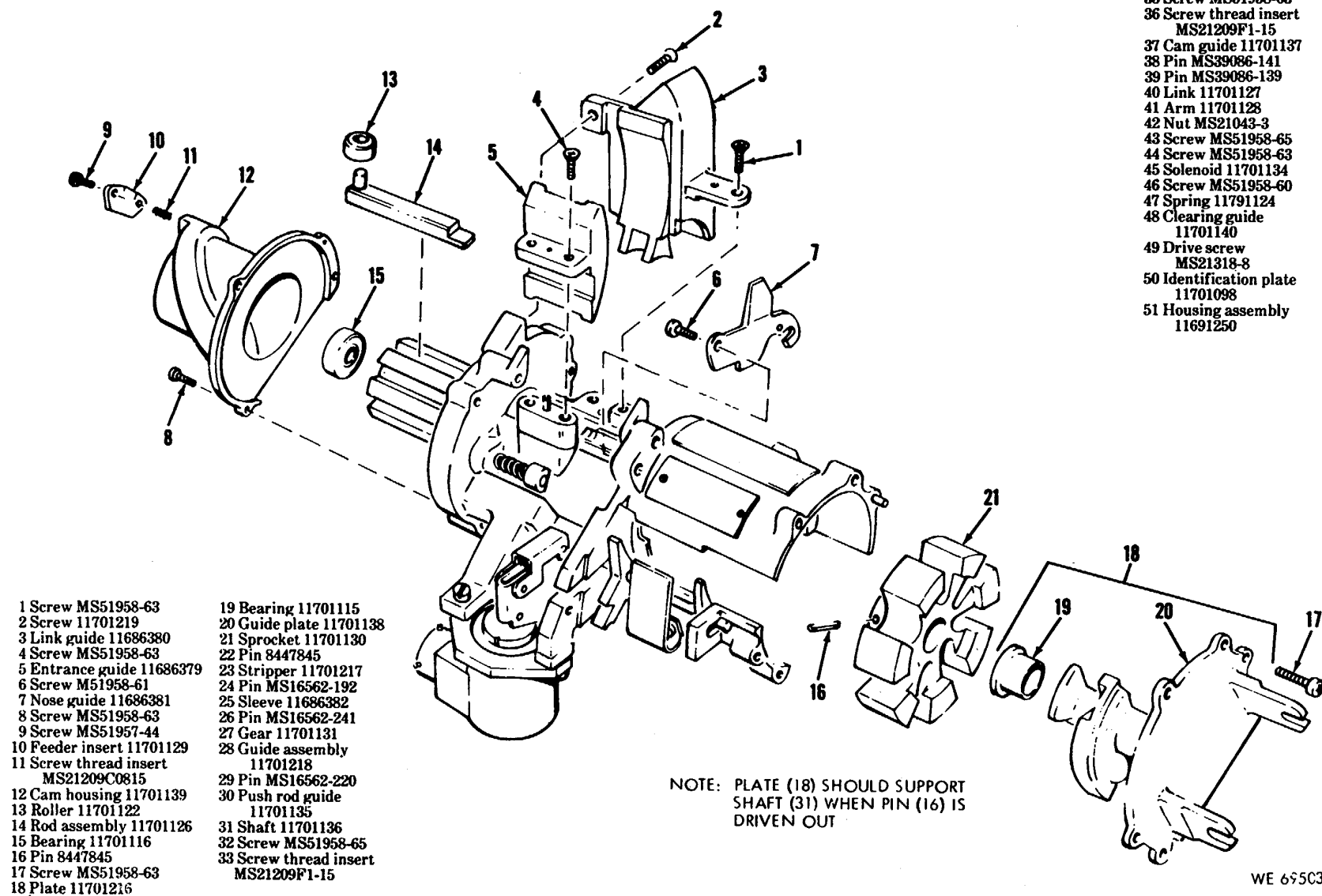
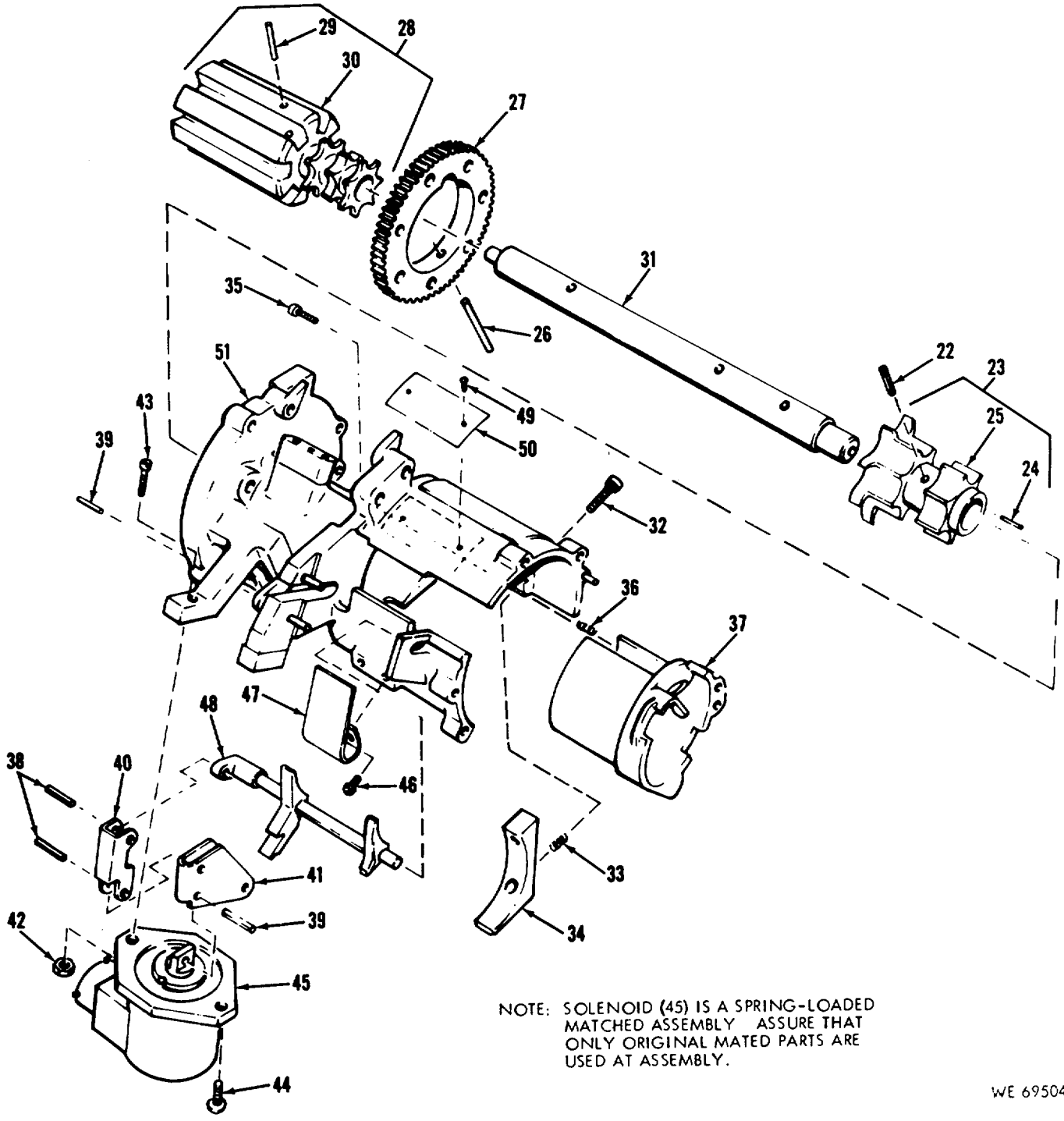

Figure 3-4. Delinking feeder MAU-56/A-exploded view (sheet 1 of 2)



NOTE: SOLENOID (45) IS A SPRING-LOADED MATCHED ASSEMBLY. ASSURE THAT ONLY ORIGINAL MATED PARTS ARE USED AT ASSEMBLY.

WE 69504

Figure 3-4. Delinking feeder MAU/56-A-exploded view (sheet 2 of 2)

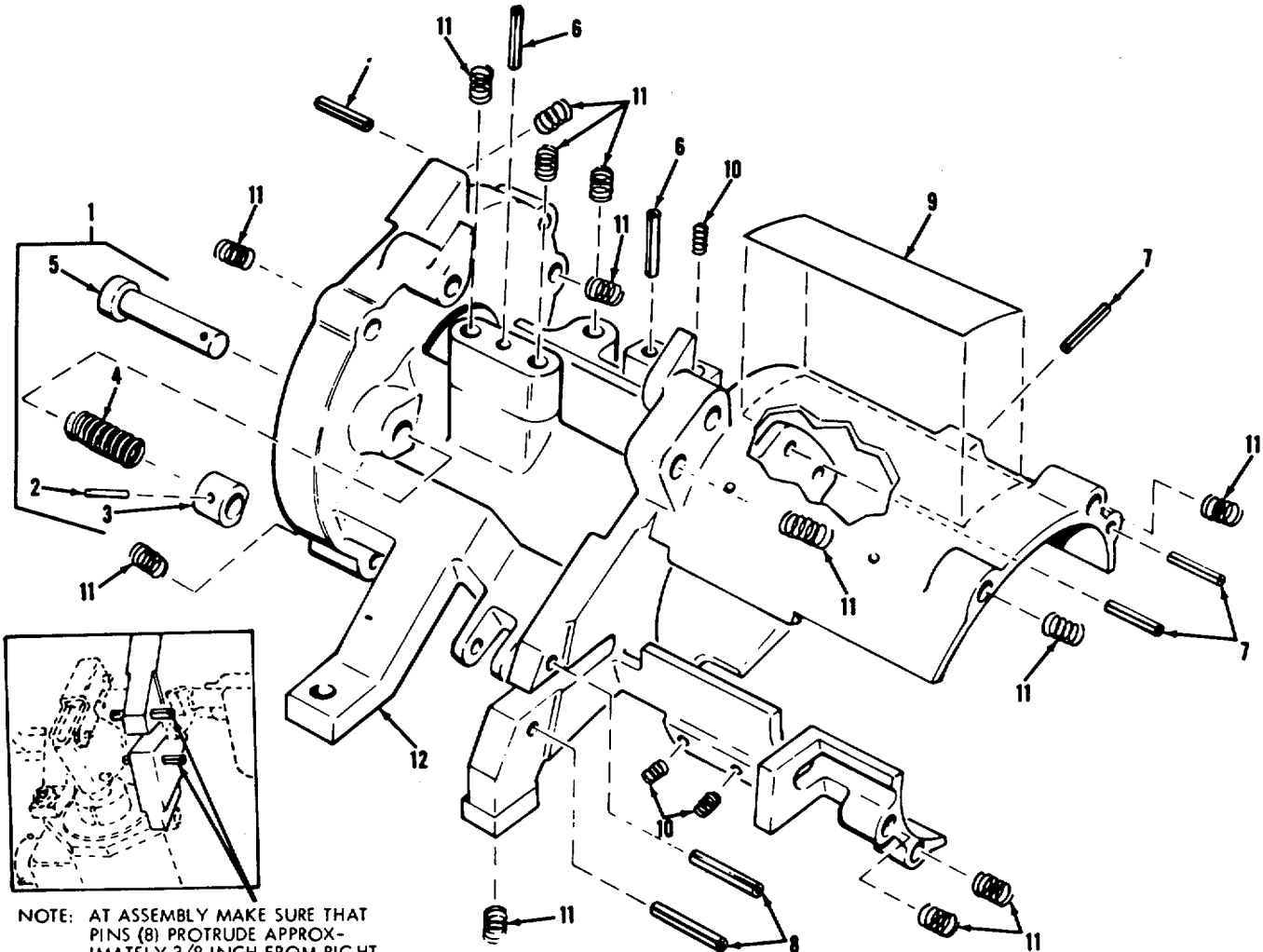

NOTE: AT ASSEMBLY MAKE SURE THAT PINS (8) PROTRUDE APPROXIMATELY 3/8 INCH FROM RIGHT SIDE OF HOUSING.

WE 69505

- 1 Timing pin set 5910338
- 2 Pin MS16562-194
- 3 Button 11701056
- 4 Spring MS24585-1156
- 5 Pin 11701055
- 6 Pin MS16562-221
- 7 Pin MS16562-223
- 8 Pin MS 39086-143
- 9 Instruction plate 11701125
- 10 Insert 11014567
- 11 Insert MS21209F1-15
- 12 Housing 11686378

Figure 3-4.1. Feeder housing assembly—exploded view.

By the Order of the Secretary of the Army:

Official:

VERNE L. BOWERS,
*Major General, United States Army,
The Adjutant General.*

W. C. WESTMORELAND,
*General, United States Army,
Chief of Staff*

Distribution:

To be distributed in accordance with DA Form 12-31, (qty rqr block no. 129) Direct and General Support maintenance requirements for 7.62MM Machine Gun Armament Subsystem XM27E1.

Changes in force C 1, C 2, and C 3

CHANGE }
NO. 3 }

HEADQUARTERS
DEPARTMENT OF THE ARMY
WASHINGTON, DC, 17 December 1975

Aviation Intermediate Maintenance Manual

**ARMAMENT SUBSYSTEM, HELICOPTER
7.62 MILLIMETER MACHINE GUN:
HIGH RATE M27E1
(NSN 1005-00-933-6242)
(USED ON OH-6A HELICOPTERS)**

TM 9-1005-298-34 30 July 1969, is changed as follows:

The title is changed as shown above.

Page i. Immediately following the title add the following:

To implement the three level maintenance concept, the following changes will be made to this manual, as applicable:

a. Substitute the words Aviation Unit maintenance for Crew/Operator and Organizational maintenance (first level of maintenance). Also, wherever the symbol for Crew/Operator maintenance (C) is used, change to the symbol for Aviation Unit maintenance (O).

b. Substitute the words Aviation Intermediate maintenance for Direct Support and General Support maintenance (second level of maintenance). Also, wherever the symbol for General Support maintenance (H) is used, change to the symbol for Aviation Intermediate maintenance (F).

c. The Depot level of maintenance remains the same (third level of maintenance).

d. Under the new three level maintenance concept, the maintenance codes are as follows: Aviation Unit Maintenance (O), Aviation Intermediate Maintenance (F), and Depot Maintenance (D).

By Order of the Secretary of the Army:

FRED C. WEYAND
*General, United States Army
Chief of Staff*

Official:

PAUL T. SMITH
*Major General, United States Army
The Adjutant General*

Distribution:

To be distributed in accordance with DA form 12-31 (qty req block No. 412), Direct/General Support requirements for 7.62-MM Machine Gun, High Rate, M27.

TECHNICAL MANUAL

No. 9-1005-98-34

}

HEADQUARTERS,
DEPARTMENT OF THE ARMY
WASHINGTON, D. C., 30 July 1969**DIRECT AND GENERAL SUPPORT MAINTENANCE MANUAL****ARMAMENT SUBSYSTEM, HELICOPTER,
7.62 MILLIMETER MACHINE GUN:
HIGH RATE, XM27E1
(1005-933-6242)
(USED ON OH-6A HELICOPTER)***This manual is current as of 24 February 1969.*

	Paragraphs	Pages
CHAPTER 1. INTRODUCTION		
SECTION I. General-----	1-1, 1-2	1-1
SECTION II. Description and data-----	1-3, 1-4	1-3
CHAPTER 2. DIRECT AND GENERAL SUPPORT MAINTENANCE INSTRUCTIONS		
SECTION I. Repair parts, special tools, and equipment -----	2-1, 2-2	2-1
SECTION II. Troubleshooting-----	2-3	2-1
SECTION III. Preembarkation inspection of material in units alerted for overseas movement -----	2-4, 2-5	2-10
SECTION IV. General maintenance -----	2-6, 2-9	2-10
SECTION V. Removal and installation of major components -----	2-10	2-14
CHAPTER 3. REPAIR OF GUN ASSEMBLY		
SECTION I. Gun assembly -----	3-1	3-1
SECTION II. 7.62 Millimeter gun M134 -----	3-2, 3-3	3-1
SECTION III. Delinking feeder MAU-56/A -----	3-4, 3-6	3-5, 3-9
SECTION IV. Electric gun drive assembly-----	3-7, 3-11	3-9, 3-10
SECTION V. Sensing unit and cable assembly -----	3-12, 3-13	3-13
CHAPTER 4. REPAIR OF FAIRING ASSEMBLY -----	4-1, 4-3	4-1
CHAPTER 5. REPAIR OF MOUNT ASSEMBLY		
SECTION I. Mount assembly -----	5-1, 5-3	5-1
SECTION II. Ammunition container assembly -----	5-4, 5-5	5-3
SECTION III. Electrical system assembly -----	5-6, 5-7	5-5
SECTION IV. Housing and tube assembly -----	5-8, 5-10	5-16
CHAPTER 6. REPAIR OF HELICOPTER REFLEX SIGHT XM70E1 -----	6-1, 6-6	6-1
CHAPTER 7. FINAL INSPECTION-----	7-1	7-1
APPENDIX A. REFERENCES-----		A-1

*This manual supersedes TM 9-1005-298-35, 19 May 1967.

CHAPTER 1

INTRODUCTION

Section I. GENERAL

1-1. Scope

a. This manual contains instructions for direct and general support maintenance of armament subsystem XM27E1 (fig. 1-1).

b. The maintenance allocation chart in TM 9-1004-28-12 allocates maintenance responsibilities.

1-2. Forms and Records

a. *Authorized Forms.* DA Forms and procedures used for equipment maintenance will be only those prescribed in TM 38750, Procedures. Refer to DA Pam

310-2 for a listing of all forms.

b. *Recommendations for Maintenance Manual Improvements.* Report of errors, omissions, and recommendations for improving this publication by the individual user is encouraged. Reports should be submitted on DA Form 2028 (Recommended Changes to DA Publications) and forwarded direct to: Commanding General, U. S. Army Weapons Command, ATTN: AMSWE-SMM-P, Rock Island, Illinois 61201.

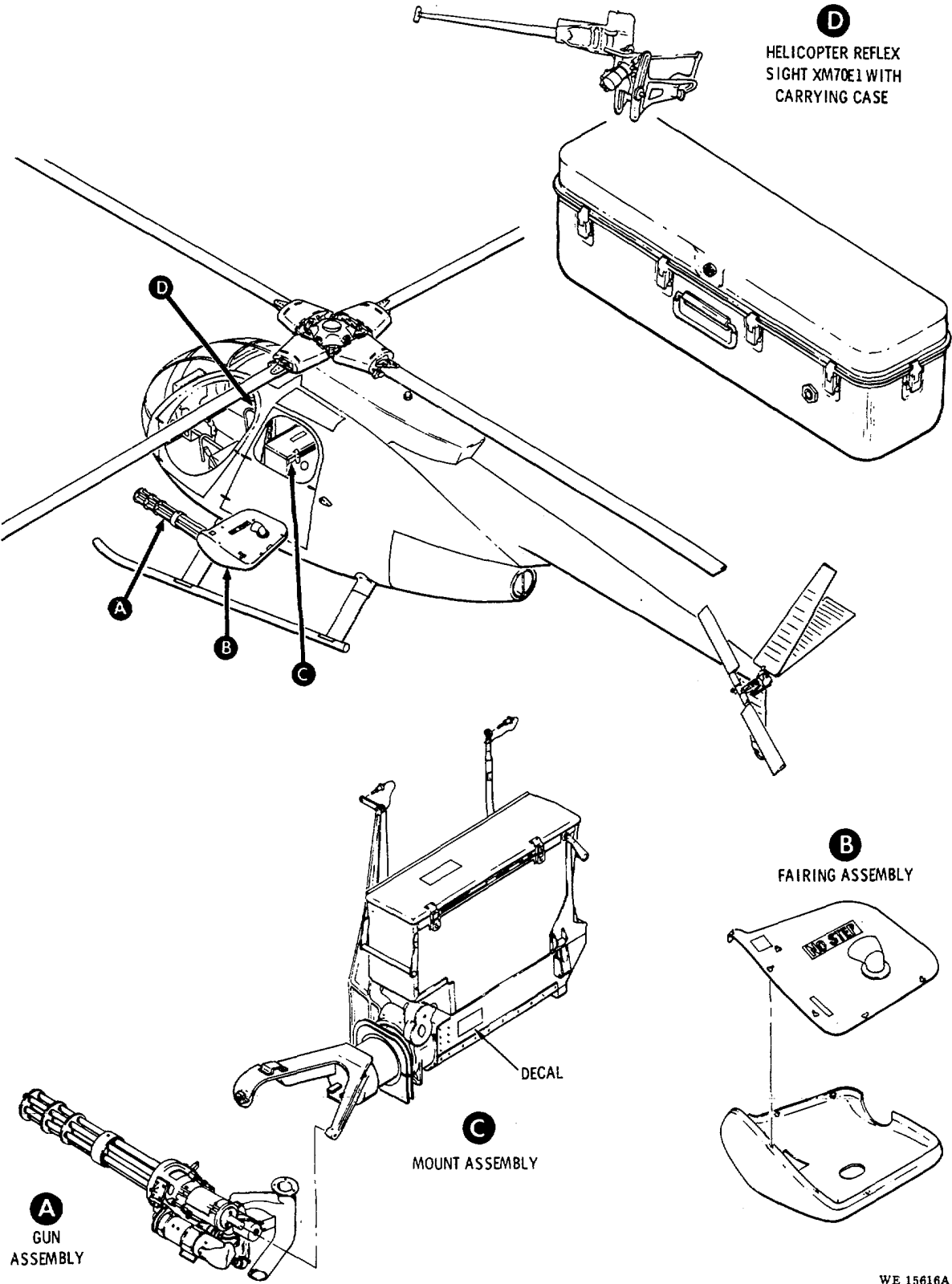

WE 15616A

Figure 1-1. Components of the armament subsystem XM27E1.

Section II. DESCRIPTION AND DATA

1-3. Description

Refer to TM 9-1005-298-12.

1-4. Tabulated Data

Refer to TM 9-1005-298-12.

**CHAPTER 2
DIRECT AND GENERAL SUPPORT
MAINTENANCE INSTRUCTIONS**

Section I. REPAIR PARTS, SPECIAL TOOLS AND EQUIPMENT

2-1. Special Tools and Equipment

Special tools and equipment are listed in TM 9-1005-298-35P and in table 2-1.

2-2. Direct and General Support Maintenance Repair Parts

Direct and general support maintenance repair parts are listed and illustrated in TM 9-1005-298-35P.

Section II. TROUBLESHOOTING

2-3. General

Troubleshooting is presented in two tables. Table 2-2 provides troubleshooting for defective mechanical components and table 2-3 provides troubleshooting for the electrical system. The tables include tests and corrective actions applicable to direct support and general support levels of maintenance and should be

considered an extension of the organizational level troubleshooting tables to be found in TM 9-1005-298-12

a. When performing electrical troubleshooting, test equipment will be required as noted in the procedures. The schematic diagram, figure 2-1 and wiring diagram, figure 2-2, should be used as an aid in tracing the circuits.

Table 2-1. Special Tools and Equipment

Identifying Item	Number	Reference		Name and use
		Fig.	Para.	
1	111697520 (composed of 11697521, 11697522, and 11697523)	5-11	5-10	Too combination for adjusting the forward bearing housing assembly.
2	182350		6-4	Dioptometer, Keuffel and Esser No. 182350 (or equivalent), to check focus of sight projector reticle.
3	10547466 (4931-936-54031	6-9	6-6	Fixture for final inspection and collimation of sight X-M70E1.

b. Connect external 28 VDC electrical power to the aircraft to prevent excessive battery drain.

c. When a troubleshooting check calls for energizing the system, the armament panel and aircraft controls will be positioned as follows:

Warning: Do not attempt to troubleshoot a loaded weapon. Be sure no ammunition is present in any subsystem component before energizing the system.

(1) BATT-OFF-EXT switch at EXT (or BATT if external power is not available).

(2) ARM and ARM POWER circuit breakers depressed.

(3) MODE MASTER switch at FIRE NORM.

(4) ARM-SAFE switch at ARM.

(5) Normal indications at this time will be GUN NOT CLEARED light off, ARMED light on, and AMMO LOW light on.

Note. A preliminary test of all indicator lights on the armament panel can be made by depressing the LIGHTS TEST pushbutton at the upper center of the air-craft instrument panel electrical equipment repairman.

d. When electrical troubles are isolated to aircraft wiring or component, notify the aircraft electrical equipment repairman.

Table 2-2. Troubleshooting Mechanical Components

Malfunction	Probable cause	Corrective action
<p>Gun fails to rotate</p> <p>Damaged delinking feeder.</p> <p>Gun stops firing</p> <p>Gun fails to feed</p> <p>Gun fails to extract</p>	<p style="text-align: center;">Gun Assembly</p> <p>Defective drive motor.</p> <p>Replace or repair as required.</p> <p>Damaged rotor assembly.</p> <p>Damaged or broken guide bar.</p> <p>Bent or broken fingers on gun housing.</p> <p>Damaged or broken extractor on bolt head.</p> <p>Bent or broken guide bar allows round to feed ahead of bolt assembly.</p> <p>Damaged or broken extractor on bolt head.</p> <p>Damaged gun housing.</p>	<p>Replace driver motor or repair as required.</p> <p>Repair rotor assembly.</p> <p>Replace guide bar.</p> <p>Repair or replace housing.</p> <p>Replace firing bolt head assembly.</p> <p>Replace guide bar.</p> <p>Replace firing bolt assembly.</p> <p>Replace gun housing.</p>
<p>Mount will not elevate or depress</p> <p>Ammunition does not feed properly.</p>	<p style="text-align: center;">Mount Assembly</p> <p>Defective clutch or drive gearing.</p> <p>Defective gear sector or worm gear.</p> <p>Torque tube binds in housing.</p> <p>Defective feed chute or elbow chute.</p> <p>Worn or defective rollers or levelers in ammunition container.</p>	<p>Repair or replace as required.</p> <p>Repair or replace torque tube assembly.</p> <p>Replace torque tube assembly.</p> <p>Repair or replace as required.</p> <p>Repair or replace as required.</p>
<p>Reticle pattern not centered on beamsplitter.</p> <p>Reticle pattern canted from vertical and horizontal.</p> <p>Reticle pattern not clear and sharp.</p> <p>Elevation control knob binding.</p> <p>Looseness between fitted parts of sight.</p>	<p style="text-align: center;">Helicopter Reflex Sight XM70E1</p> <p>Bent or damaged beamsplitter arm.</p> <p>Locking detent worn or damaged.</p> <p>Reticle not properly positioned in projector.</p> <p>Optical elements not positioned for proper focus.</p> <p>Defective rheostat.</p> <p>Moisture inside projector due to failure of hermetic sealing.</p> <p>Improper lubrication or contamination.</p> <p>Bent shaft.</p> <p>Excessive wear.</p> <p>Improper tightening of attaching parts.</p>	<p>Replace arm assembly or beamsplitter.</p> <p>Repair or replace.</p> <p>Adjust reticle or projector assembly.</p> <p>Adjust as required or replace projector.</p> <p>Replace rheostat.</p> <p>Repair as required or replace projector.</p> <p>Disassemble, clean, and lubricate.</p> <p>Replace.</p> <p>Repair or replace as required.</p> <p>Tighten as required.</p>

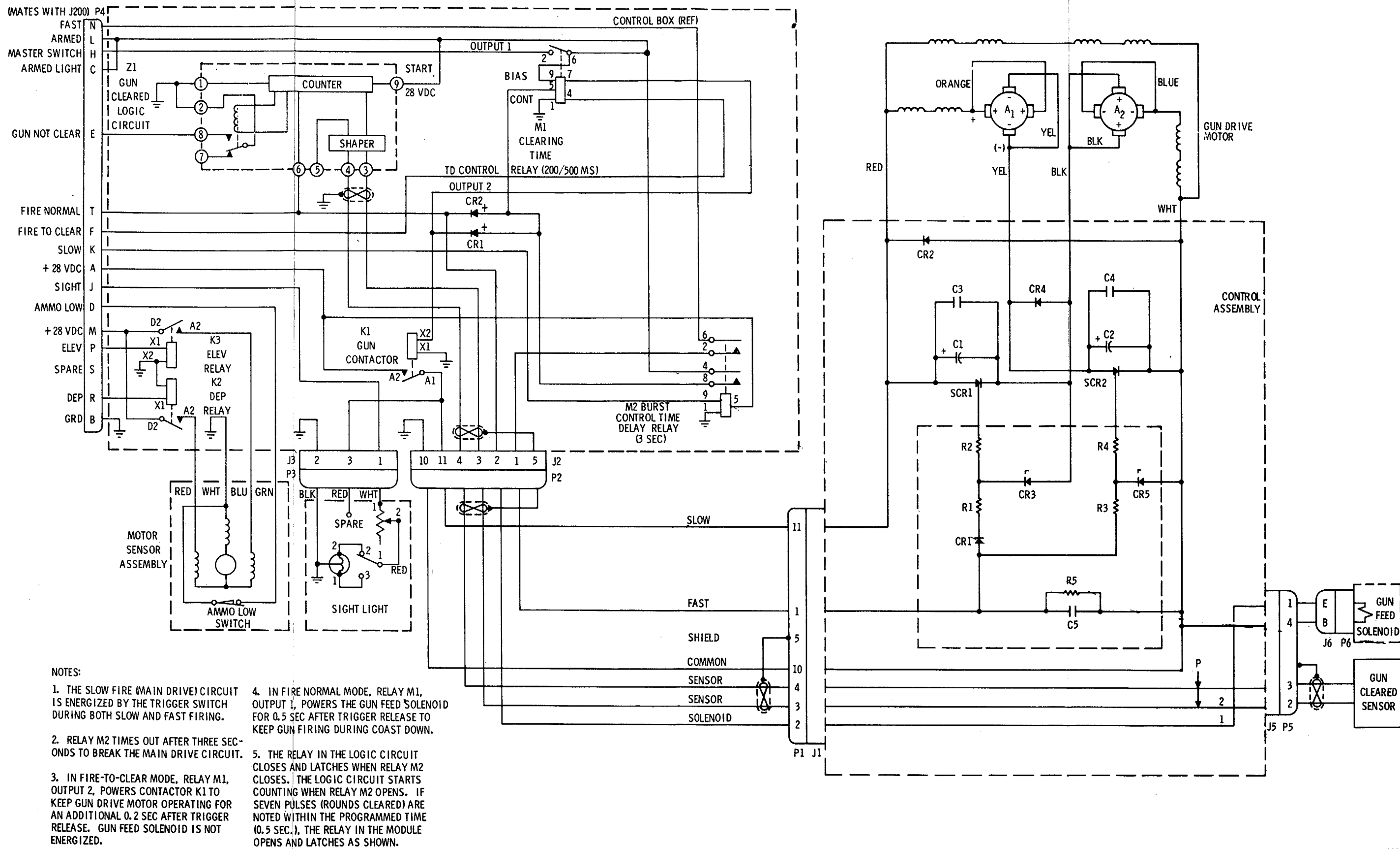

Figure 2-1. Schematic diagram-armament subsystem XM27E1.

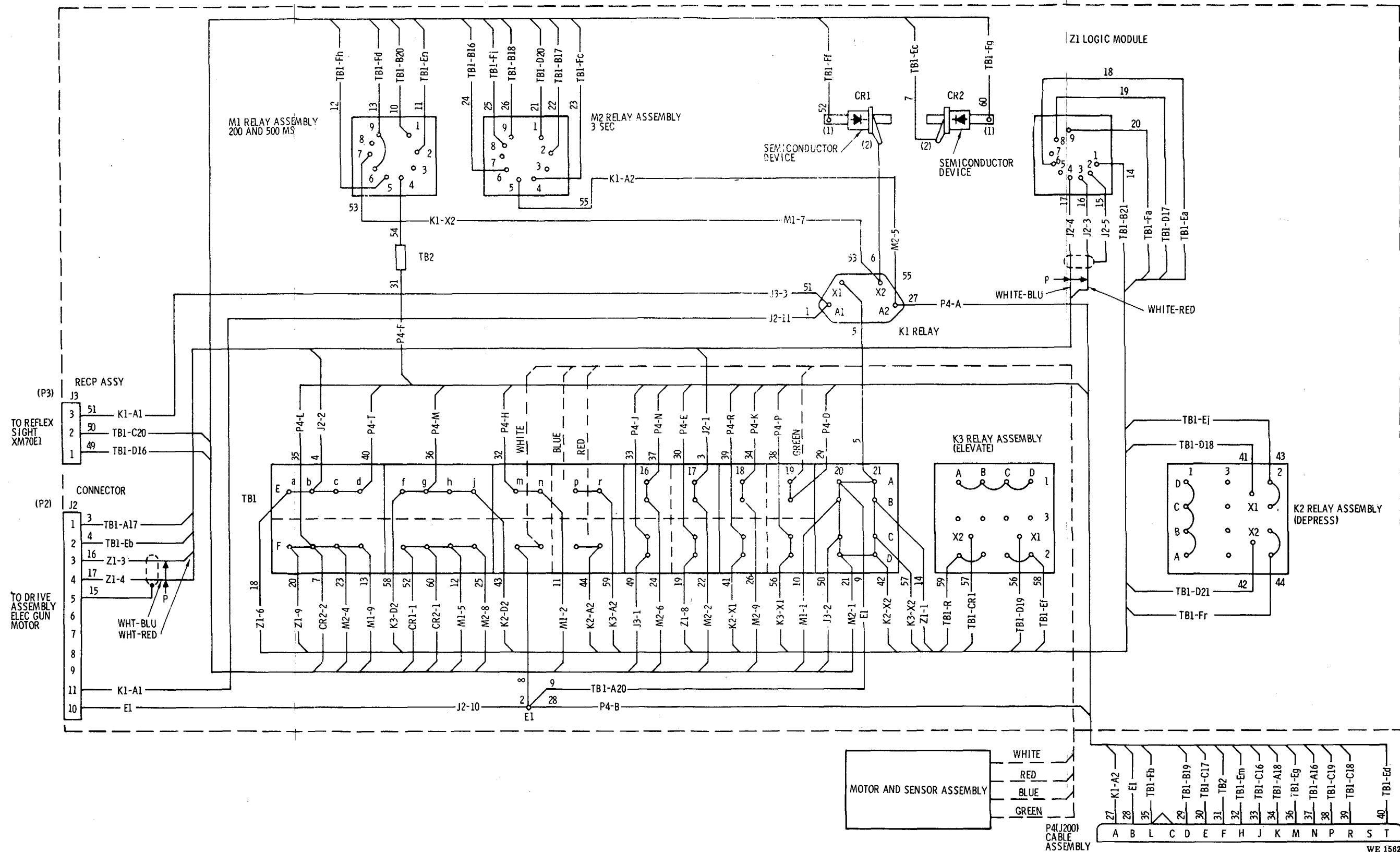

Figure 2-2. Wiring diagram-control box.

Table 2-3. Troubleshooting Electrical System

Malfunction	Probable cause	Action required for check	Check between	Normal meter reading (supply voltage 28 VDC)	Procedure	
					Meter reading normal	Meter reading abnormal
<p>Note. During electrical troubleshooting, do not operate gun drive motor except when specifically required. Disconnect gun drive cable plug P1 or P2 to prevent operation.</p>						
Gun does not rotate. Fault traced to control box (ref TM 9-1005-298-12).	Faulty gun contactor K1 or relay M2. tern and hold trigger at first detent	Disconnect plug P2, at control box cover, energize system. <i>Note.</i> Burst control relay M2 will open after three seconds. Release trigger and depress again to reenergize the firing circuit.	J2-10 and J2-11 Contactor K1-A1 and GRD.	28 VDC 28 VDC	No fault Check wiring from K1-A1 to J2-11.	Continue checks. Continue checks.
			Contactor K1-X2 and GRD.	28 VDC	Replace contactor K1.	Continue checks.
			Relay M2-8 and GRD.	28 VDC	Replace diode CR1	Continue checks
			Relay M2-9 and GRD.	28 VDC	Continue checks.	Check box wiring to P4-K and through aircraft wiring to trigger switch.
Gun rotates at slow rate but does not switch to fast rate. Fault traced to control box.	Faulty relay M2, or trigger switch.	Same as preceding except trigger depressed to second detent	J2-1 and J2-10	28 VDC	No fault	Check box wiring to P4-L and through aircraft wiring to ARMED switch. Check box wiring to relay M2, pin 2.
			Relay M26 and GRD.	28 VDC	Replace relay M2 (contacts not closing).	Check box wiring to P4-N and through aircraft wiring to trigger switch.
Gun rotates but ejects live ammo. Fault traced to control box.	Faulty diode CR2	Same as preceding except master switch at FIRE TO CLEAR.	J2-2 and J2-10.	28 VDC	No fault	Check box wiring from J2-2 to CR2.
			Each side of CR2 and GRD.	28 VDC	No fault	Replace CR2.

Table 2-3. Troubleshooting Electrical System—Continued

Malfunction	Probable cause	Action required for check	Check between	Normal meter reading (supply voltage 28 VDC)	Procedure	
					Meter reading normal	Meter reading abnormal
GUN NOT CLEARED light remains on after firing to clear. (Seven or more rounds ejected; sensor not at fault).	Faulty module Z1	Energize system, depress RESET button on control box then release.	Z1-7 and Z1-8.	No continuity	Check circuit from Z1-8 to P4-E and aircraft cir- cuit for short to ground.	Replace Module Z1.
			J2-3 and Z1-3.	Continuity	Continue checks	Repair box wiring.
			J2-4 and Z1-4. Z1-6 and GRD.	Continuity 28 VDC	Continue checks Continue checks.	Repair box wiring. Refer to checks for faulty diode CR2.
			Z1-9 and GRD.	28 VDC	Replace Module Z1.	Check box circuit to P4-L and air- craft to ARMED switch.
Gun clearing op- eration faulty—too few or too many rounds cleared.	Faulty M1 clearing time relay.	Disconnect plug P2, and energize system in FIRE TO CLEAR with trigger at first detent.	J2-11 and J2-10.	28 VDC with trigger depressed Zero VDC almost imme- diately (200ma) after trigger release.	No fault.	Replace clearing time relay.
Gun does not elevate (motor not at fault).	Faulty relay K3	Hold pilot's switch at ELEV.	K3-X1 and GRD.	28 VDC	Continue checks.	Check box circuit to P4-P, aircraft wiring, and ELEV. switch.
Gun does not depress (motor not at fault).	Faulty relay K2	Hold pilot's switch at DEP.	K3-A2 and GRD. K2-X1 and GRD.	28 VDC 28 VDC	No fault. Continue checks.	Replace relay K3. Check box circuit to P4-R, aircraft wiring and DEP switch.
			K2-A2 and GRD.	28 VDC	No fault.	Replace relay K2.
AMMO LOW indi- cation erratic.	Faulty sensor switch	Disconnect plug P4 at aircraft recep- tacle J200. Depress sensor switch.	P4-D and GRD.	No continuity	Check aircraft cir- cuit by applying ground to J200-D AMMO LOW lamp should light.	Replace sensor switch.

Table A. Troubleshooting Electrical System--Continued

Malfunction	Probable cause	Action required for check	Check between	Normal meter reading (supply voltage 28 VDC)	Procedure	
					Meter reading normal	Meter reading abnormal
AMMO LOW indication erratic-continued. Reflex sight light operation faulty.	Faulty lamp, wiring or rheostat	Release sensor switch.	P4-D and GRD.	Continuity	No fault.	Replace sensor switch.
		Disconnect plug P3 and energize system.	J3-1 and J3-2.	28 VDC	No fault.	Check box circuit from J3-1 to P4-J and aircraft circuit to panel.
		Rotate rheostat knob CW then CCW. Switch lamp filaments and repeat.	P3-1 and P3-2.	Decrease in resistance at full CW. Increased resistance at full CCW.	No fault.	Repeat test using lamp known to be good. Check rheostat Continuity at contacts inside lamp housing.

Section III. PREEMBARKATION INSPECTION OF MATERIAL IN UNITS ALERTED FOR OVERSEAS MOVEMENT

2-4. General

a. Pre-Inspection Points

Warning: Clear weapon before starting inspection (refer to TM 9-1005-298-12). Point weapon in a safe direction and determine if live rounds are present. Check bore and chamber for obstructions; for example, a bullet in the bore or a ruptured cartridge case in the chamber.

The subsystem must be thoroughly cleaned of all grease, dirt, or other foreign matter that might interfere with its proper function, or obscure the true condition of parts.

b. Inspection Points.

(1) Screw heads must be in serviceable condition, and threads must not be stripped. Internal threads must not be stripped.

(2) Cable assemblies must not have loose or damaged connections, cut or worn insulation, broken wires, kinks, or sharp bends.

(3) Material must be free of burrs, particularly those on functional surfaces.

(4) Parts must not be cracked, bent, distorted or damaged, and must be free of detrimental wear.

(5) Rivets must be tight.

(6) Painted surfaces must be free of bare spots.

(7) Rollers and slides must function smoothly.

(8) Welded or brazed joints must not show signs of separation or failure.

(9) Ammunition boxes and chuting must not have dents or bends that would interfere with the passing of ammunition.

(10) Check for deformed, weak, or broken springs.

(11) All locking devices shall be positive in action, and must not become disengaged due to normal operation and firing.

(12) Instruction, warning, and name plates must be present and secure.

(13) Quick release pins and similar devices must function properly and must not be subject to loss during use or transportation.

(14) Inspect links for bent or broken tabs and bent segments.

(15) Inspect electrical components for improper functioning, physical damage, and missing parts.

(16) Inspect for burned out lamps and damaged lamp covers and switches.

(17) Inspect electrical connections for damage or corrosion.

(18) Inspect optical parts for cracks, scratches, moisture on inside surface of optical cell in projector assembly, or other damage.

(19) Flexible mount must be capable of movement through full range of elevation/depression without binding.

2-5. Specific

a. 7.62 Millimeter Machine Gun M134

(1) *Bolt assembly.* Track ways must not be nicked, burred, cracked, or galled. Roller must not be worn or damaged.

(2) *Firing bolt head subassembly.* Firing pin hole must not be worn or elongated. Extractor lip must not be broken, cracked, or burred.

(3) *Helical compression spring.* Spring must be free of damage with minimum length of 1.67 inches.

(4) *Firing pin.* Striker and tank must not be worn, broken, or cracked.

(5) *Gun barrel.* Inspect for pitting, scoring excessive wear, and stripping of lands.

(6) *Timing pin.* Engage timing pin. Upon release, pin must retract clear of gun rotor.

b. *Weapon Functioning.* Manually cycle at least six rounds of M172 dummy ammunition through gun. Moving parts must operate smoothly. Rounds must chamber, extract, and eject without binding or catching and dummy ammunition must not be dented by the operation.

c. *Ammunition Feed System.* Inspect chute and crossover assembly for bent or broken areas and damaged rollers. Check for damage or defects which restrict flow of ammunition.

Section IV. GENERAL MAINTENANCE

2-6. General

Information and instructions contained herein are provided for personnel performing direct and general support maintenance on the material. Supplemental instructions for organizational personnel are contained in TM 9-1005-298-12. In subsequent chapters of this

technical manual, the main assemblies of the armament subsystem are dis-assembled, inspected, cleaned, replaced or repaired, and assembled. Refer to TM 9-1005-298-12 for removal and installation of the components of the subsystem. The illustrations in this manual are numbered in the sequence of disassembly.

When assembling, the reverse order of disassembly will be followed unless otherwise instructed. Information for direct and general support maintenance units engaged in repair for return to user is covered herein. Subsequent reference to components being worn and requiring replacement is intended to mean that only those items or mechanisms worn to a degree that affects functioning will be replaced.

2-7. General Repair Instructions- Mechanical

a. *Disassembly and Assembly Procedures.*

(1) In disassembling a unit, remove the major subassemblies first. The subassemblies may then be disassembled, as necessary, into individual parts.

(2) During assembly, subassemblies should be assembled first and then installed to form a complete unit.

(3) Complete disassembly of a unit is not always necessary in order to make a required repair or replacement. Good judgment should be exercised to keep disassembly and assembly operations to a minimum.

b. *Use of Tools.*

(1) Care must be exercised to use tools that are suitable for the task to be performed in order to avoid mutilation of parts and/or damage to tools.

(2) Keep tools clean and work with clean parts. The rules of good housekeeping must be observed.

c. *Replacement of Parts.*

(1) When pressing bushings out of or into a housing, be sure that the housing is adequately supported in the bearing area to prevent strain and distortion. An arbor press should be used if available. Alternate methods, such as the use of a hardwood block or dowel and a hammer are permissible if necessary. If a bushing has a drilled hole or groove for lubrication, be sure it is clean and properly aligned at installation. Be sure bushings are started properly and not cocked in the bore prior to applying pressure for installation.

(2) When removing or installing ball or roller bearings, the pressing force should be applied only to the race that is restrained by a mating part. Applying force to the unrestrained race will damage the bearing.

(3) During assembly of components, replace all small parts such as spring pins, screws, bolts, and nuts that show signs of wear or damage and might fail prior to

the next scheduled maintenance.

Note. Bending or failure of the pins used in assembling rotating components of the gun or delinking feeder can cause major damage due to loss of timing and synchronization.

(4) If a required new part is not available, reconditioning of the old part is required. Such parts should be examined carefully, after reconditioning, to determine that they will function properly.

d. *Welding.* For welding instructions and welding materials, refer to TM 9-237.

Caution: Welding is not to be accomplished without knowledge of physical characteristics of the metal to be welded.

(1) The link and cartridge ejection chutes are made of corrosion resistant steel. Repairs can be accomplished by spot welding, fusion welding, or brazing.

(2) Most components of the mount assembly are made of sheet or cast aluminum. Welded repairs should not be attempted. Distortion and loss of strength will be caused by welding temperatures.

e. *Repair of Damaged Threads.* Damage threads should be repaired by use of a thread restorer, by chasing on a lathe, or by use of a tap of proper dimension; damaged or defective inserts will be replaced with oversize inserts.

f. *Repair of Damaged Machined and Polished Surfaces.* Smooth rough spots, scores, burrs, galling, and gouges from damaged machine and polished surfaces so that the part will efficiently perform its normal function. The finish of the repaired part is to approximate that of the original finish. In performing any of these operations, critical dimensions must not be altered.

g. *Removal of Rust or Corrosion.* Remove corrosion from all parts of the material. To remove rust or corrosion, the use of crocus cloth, vapor blast equipment, or wipe-on type phosphoric acid metal conditioner is recommended.

h. *Finish of Metals.*

(1) Painted surfaces of the armament, if chipped or cracked, may be repainted. See TM 9-213.

(2) A class A or class B phosphate finish will be used on ferrous metals unless otherwise specified.

(3) Exposed electrical components will be coated lightly with oil varnish MIL-V-173B.

(4) A type I or II anodic coating will be applied to all aluminum or aluminum alloy parts unless otherwise specified.

(5) It will not be necessary to refinish parts that already have a good quality finish and that refinishing will not definitely improve. Replace damaged decals in accordance with TM 9-213.

(6) All parts will be free from rust, fungus and corrosion.

2-8. General Repair Instructions - Electrical

a. Use wire of same gage and length as that removed. Refer to TM 9-1005-209-35P and to electrical disassembly figures in this manual for wire specifications and terminal or contact part numbers.

b. All soldering has to be in accordance with MIL-STD-454 REQ 5. Use only non-corrosive flux.

c. Use the tools provided in supplemental tool set MOS45J for extraction and insertion of snap-in contacts in connectors and in the terminal block of the control box.

Caution: Do not attempt to pull out the snap-in contacts without using the proper extraction tool. Damage to connector or terminal block may result.

d. When replacing cable connector wires, use the following typical procedure:

(1) Slip extraction tool into socket cavity from face of connector to compress contact retaining clip. Push wire and contact out of connector. See figure 2-3.

(2) Install new contact on new wire and crimp. (Solder No. 8 contacts).

(3) Use insertion tool to push wire and contact into the connector socket cavity from rear of connector. Hold wire in place while removing insertion tool then check to be sure that contact is locked in the connector by pulling lightly on wire.

e. When replacing components having connections to the terminal block in the control box, remove and insert wire contacts as follows:

(1) Slip extraction tool over the affected wire then push tool into the terminal block socket cavity until contact retaining clip is compressed. Pull tool and wire with contact out of terminal block.

(2) To insert, slip insertion tool over wire and contact retaining clip then push tool and contact into socket cavity. Hold wire in position while withdrawing tool.

2-9. Cleaning

Caution: Do not use solvents or degreasing compounds on electrical components, rubber parts, optical components, or sealed bearings.

a. *Cleaning Mount Assembly Components.* Components of the mount assembly normally will not require extensive degreasing. The use of dip tank, vapor, or steam cleaning will not be required. These parts can be cleaned using mineral spirits paint thinner (TPM) or dry cleaning solvent (SD) and cloths, soft bristle brushes, or an air pressure spray nozzle.

b. *Cleaning Sight Assembly Components.* Wipe metal components of the sight with a cloth moistened with solvent (SD) or mineral spirits (TPM), then dry with a clean dry cloth. Clean optical components in accordance with TM 9-208-1 and TM 9-247.

c. *Cleaning Parts Requiring Degreasing.* Parts of the gun and delinking feeder may be cleaned using one of the three procedures following when extensive degreasing is required.

Caution: Be sure to remove all electrical components and all sealed bearings before using any of the following procedures

(1) *Dip-tank method.* Disassemble as required, place parts in a perforated metal basket, and submerge and agitate in a tank containing dry cleaning solvent of mineral spirits paint thinner. Repeat, using a second tank with clean solvent or thinner. Extent of treatment in each tank will depend on ease with which the preservatives are dissolved.

(2) *Vapor-degreaser method.* Tank containing a heated solution of trichlorethylene or perchlorethylene (type II) are used mostly for degreasing items that are very greasy or oily and are not rapidly cleaned by the dip-tank method.

Warning: Personnel operating vapor degreaser are cautioned not to breathe the vapor fumes.

Place parts in a perforated metal basket and submerge just below the vapors in the tank and keep there until all the grease or oil melts and runs off the parts in the basket.

(3) *Steam method.* Place parts in a perforated metal basket and steam treat until clean.

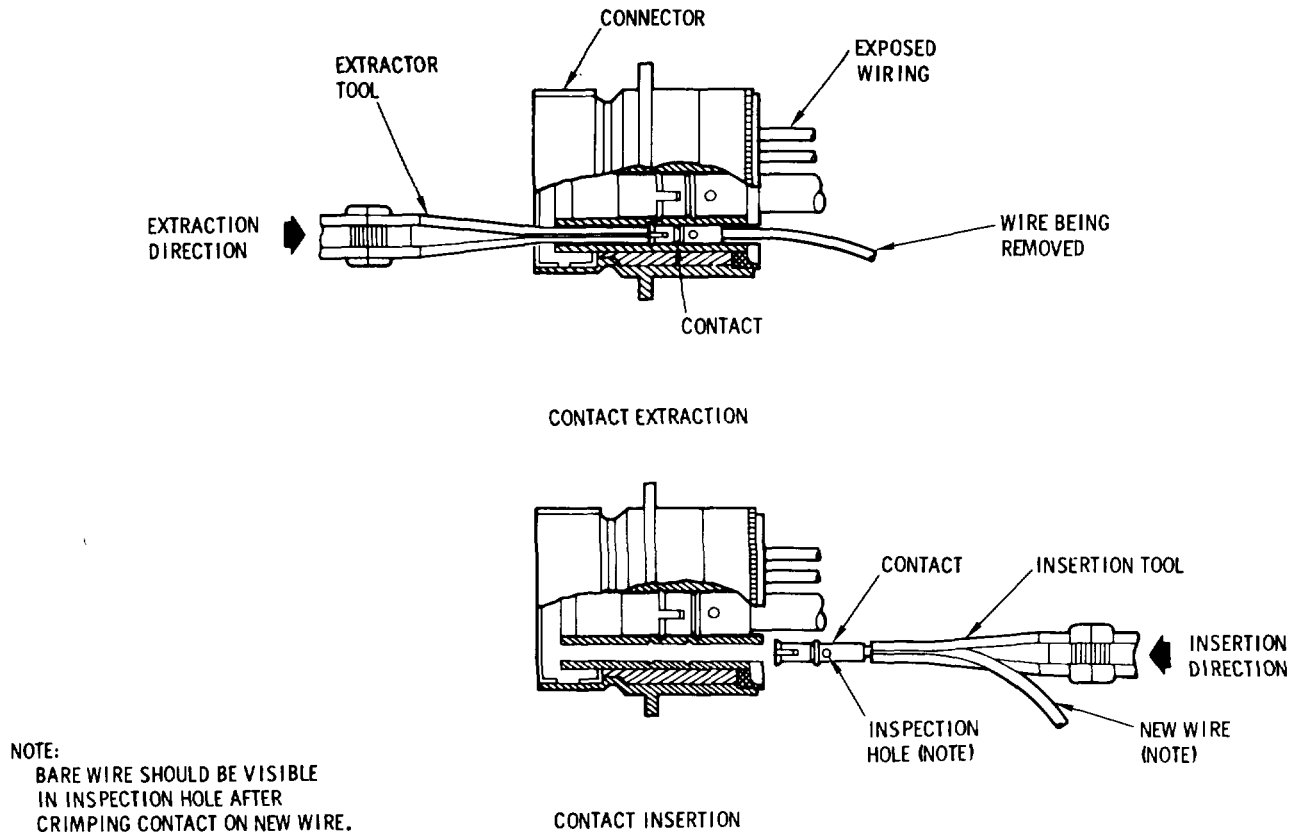

WE 61286

Figure 2-3. Connector contact extraction and insertion.

This method is less efficient than the vapor-degreaser method and may require additional cleaning of parts to remove all traces of grease or oil, particularly from recesses.

(a) If some time is to elapse before the start of repair operations, apply light grade of preservative oil to all polished metal surfaces to prevent rusting.

(b) Remove all rust spots from highly finished surfaces with a light application of crocus cloth. Use a grade 2/0 abrasive cloth on ordinary machine finished surfaces.

d. *Cleaning Gun and Delinking Feeder After Repair.*

(1) After repair operations and prior to assembly, remove shop dirt and other foreign matter from all metal surfaces. This can be done by the dip-tank method, the vapor-degreaser method, or by cleaning with cloths soaked in dry-cleaning solvent or mineral spirits paint thinner.

(2) In the dip-tank method, agitation for approximately one minute in each tank is sufficient; in the vapor-degreaser method, treatment for about two to

three minutes is sufficient.

e. *Cleaning Gun and Delinking Feeder After Shop Inspection.* After in-process shop inspections, dip parts in a tank containing fingerprint remover oil (type A), remove (use rubber gloves), and dry thoroughly by wiping with clean, lint-free, dry cloths or allow parts to drip dry. Apply preservatives as soon as possible after cleaning.

f. *Cleaning Electrical Parts.* Clean all electrical parts in accordance with TM 9-247.

g. *Cleaning Rubber Parts Other Than Electrical.* Clean rubber parts with soap and warm water. Apply coating of powdered technical talcum (Fed. Spec. ZZ-T-416) to preserve the rubber.

h. *Lubrication and Preservation.*

(1) Lubrication. Refer to LO 9-1005-298-12 for lubricating instructions for the subsystem. Lubrication that is performed during assembly is noted in the applicable assembly procedures.

(2) *Preservation.* After cleaning and drying, immediately coat unpainted metal surfaces of gun and

delinking feeder with lubricating oil (LSA-T) in accordance with LO 9-1005-298-12.

Section V. REMOVAL AND INSTALLATION OF MAJOR COMPONENTS

2-10. Removal/Installation

Refer to TM 9-1005-298-12 for applicable procedures.

CHAPTER 3
REPAIR OF GUN ASSEMBLY

Section I. GUN ASSEMBLY

3-1. Disassembly/Assembly

The gun assembly is disassembled and assembled at organizational level. Refer to TM 9-1005-298-12.

Individual major components requiring further disassembly and assembly are covered in subsequent sections of this chapter.

Section II. 7.62 MILLIMETER MACHINE GUN M134

3-2. Disassembly/Assembly

The gun is disassembled in the order of item numbers shown on figures 3-1, 3-2, and 3-3. Assembly is performed in reverse order. Read the general repair instructions for mechanical components (para 2-7) prior to start of work.

3-3. Cleaning, Inspection, and Repair

- a. *Cleaning.* Refer to paragraph 2-9.
- b. *Inspection.* Refer to general repair instruction table in TM 9-10(-298-12).
- c. *Repair.* Refer to general repair instructions for mechanical components (para 2-7).

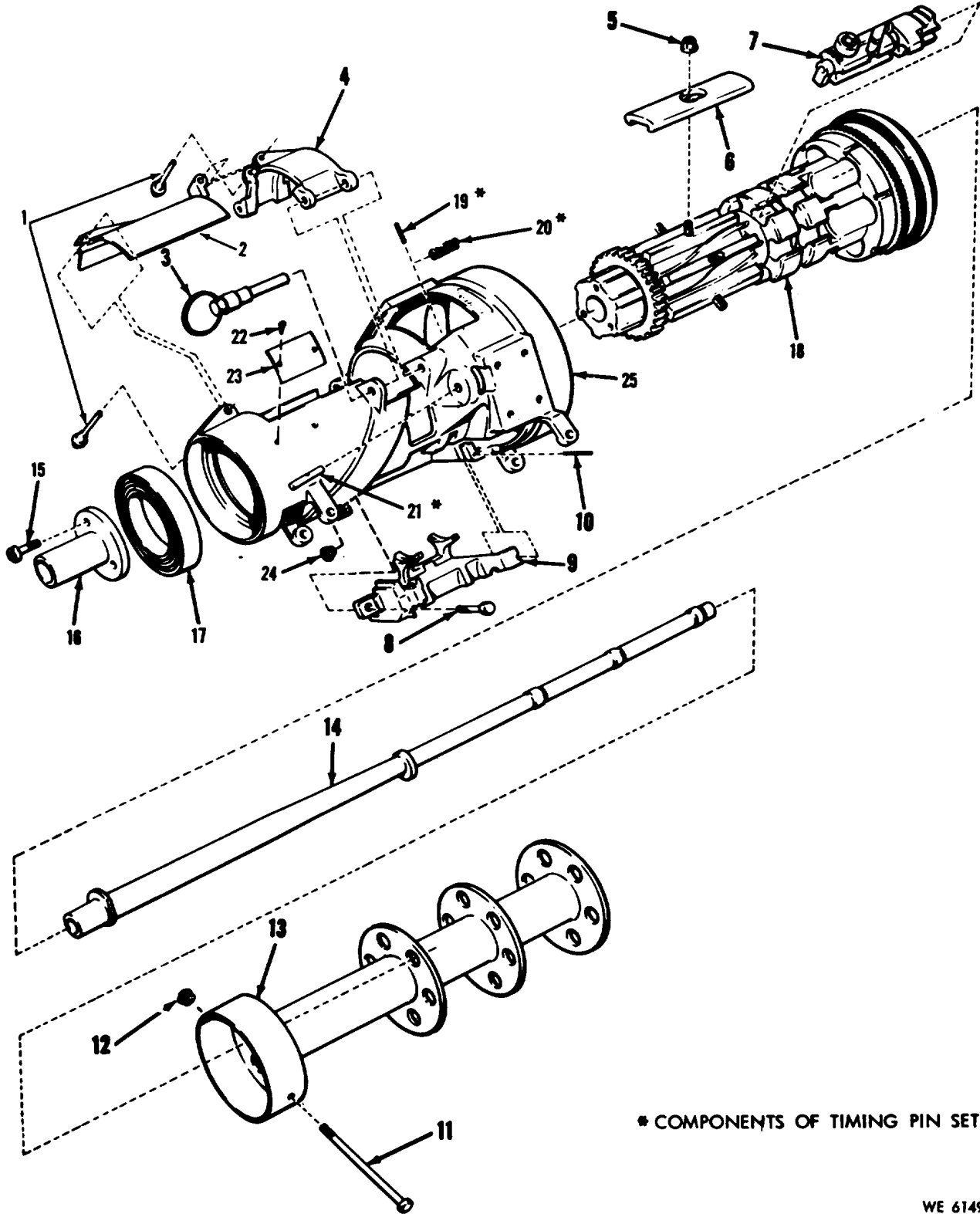

WE 61490

Figure 3-1. 7.62 Millimeter machine gun M134 exploded view.

1-Pin
2-Cover
3-Pin
4-Safing sector
5-Nut
6-Track
7-Bolt assembly
8-Screw
9-Bar

10-Pin
11-Bolt
12-Splined nut
13-Barrel clamp
14-Barrel
15-Screw
16-Support
17-Bearing
18-Rotor assembly

19-Pin
20-Spring
21-Pin
22-Drive screw
23-Identification plate
24-Insert
25-Gun housing

Figure 3-1—Continued.

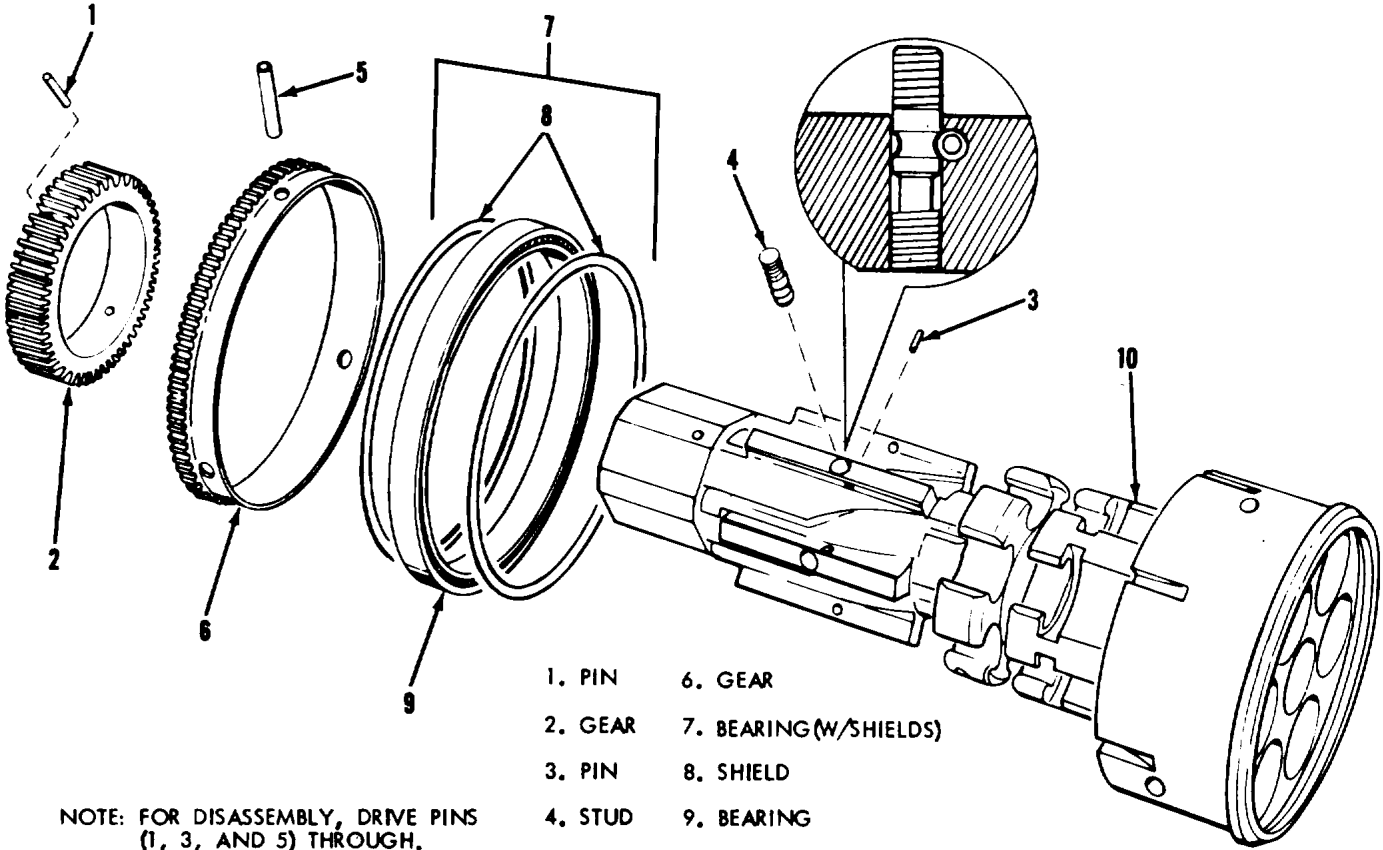

WE 61487

Figure 3-2. Rotor assembly-exploded view.

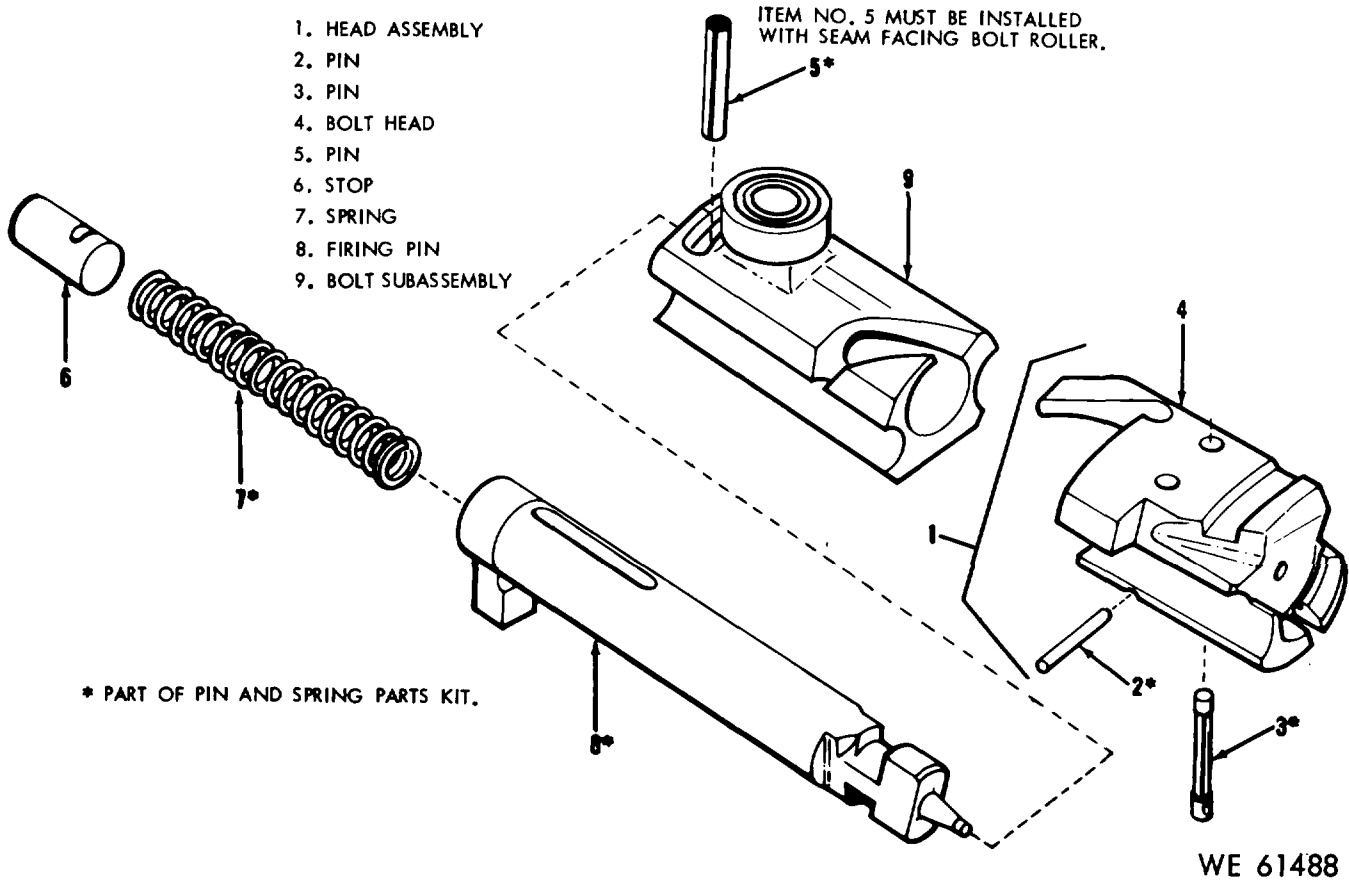

Figure 3-3. Bolt assembly-exploded view.

Section III. DELINKING FEEDER MAU-56/A

3-4. Description

The delinking feeder provides a flow of delinked ammunition to the gun and is powered, through gearing, by the gun. Additional descriptive information will be found in TM 9-1005-29812.

3-5. Disassembly/Assembly

The delinking feeder is disassembled in the order of item numbers shown on figure 3-4. Assembly is performed in reverse order. Read the general repair instruction for mechanical components (para 2-7) prior to start of work.

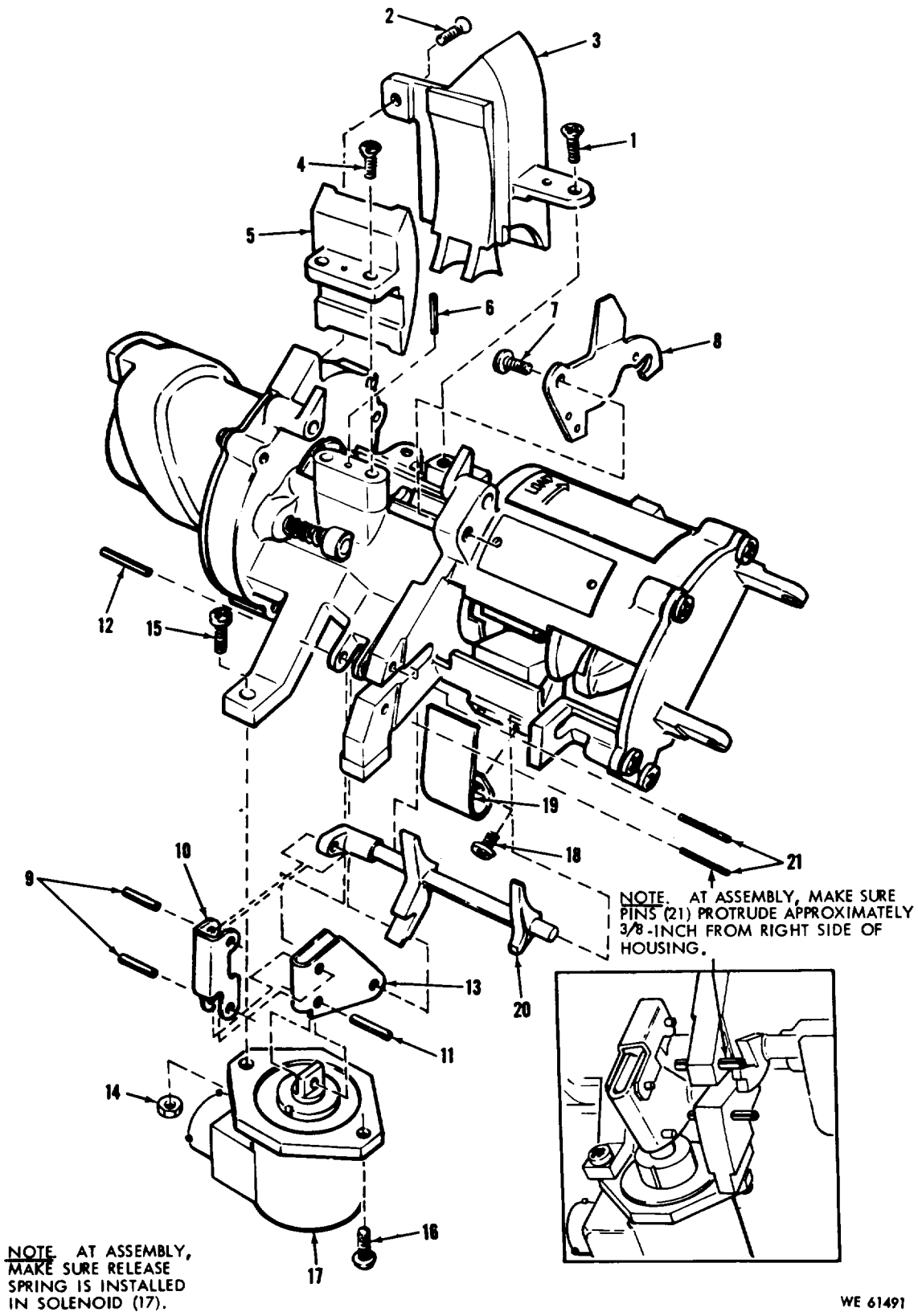
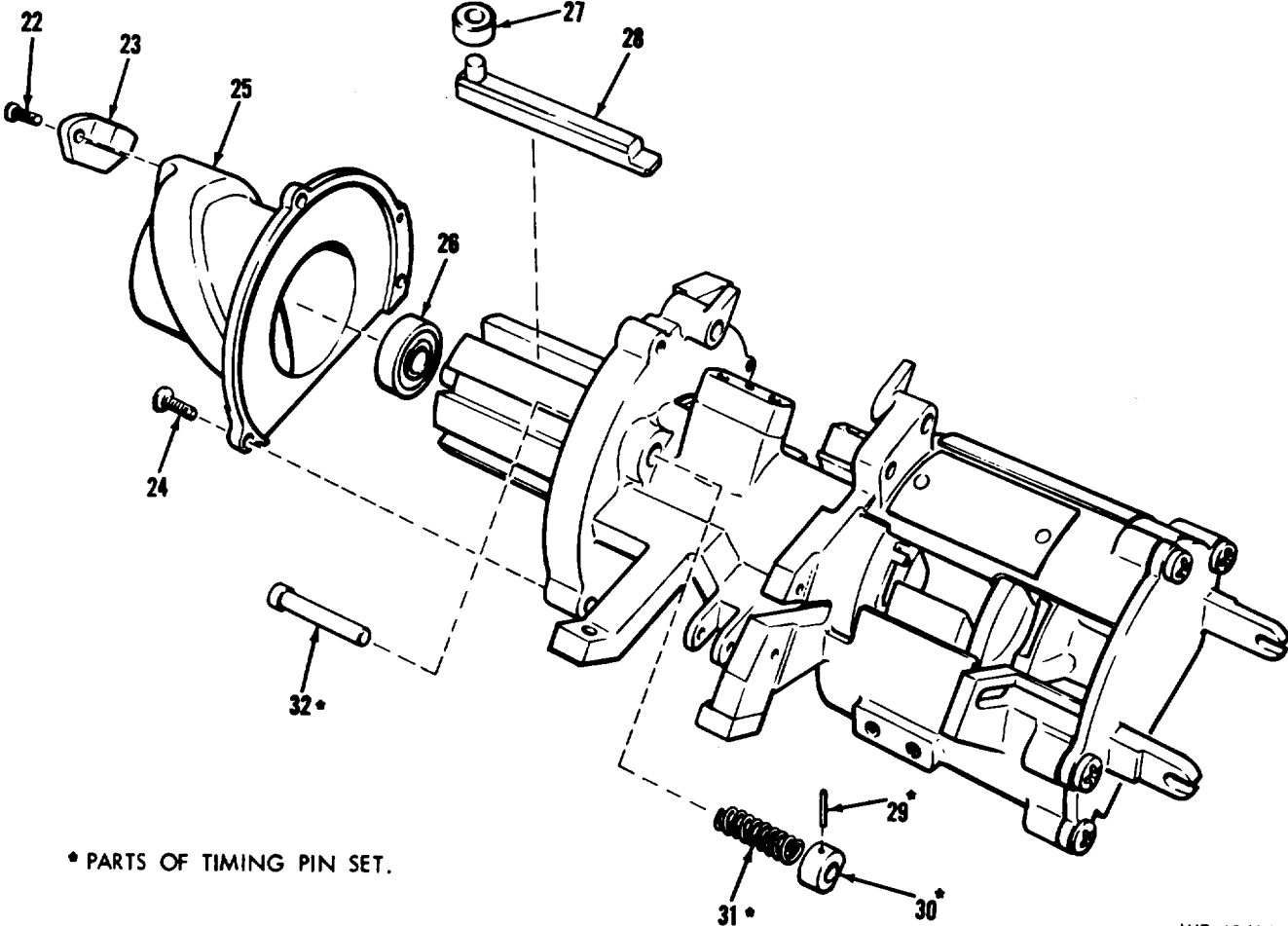

Figure 3-4. Delinking feeder MAU-56/A-exploded view (sheet 1 of 3).



* PARTS OF TIMING PIN SET.

WE 61494

Figure 3-4. Delinking feeder MA U-56/A—exploded view (sheet 2 of 3).

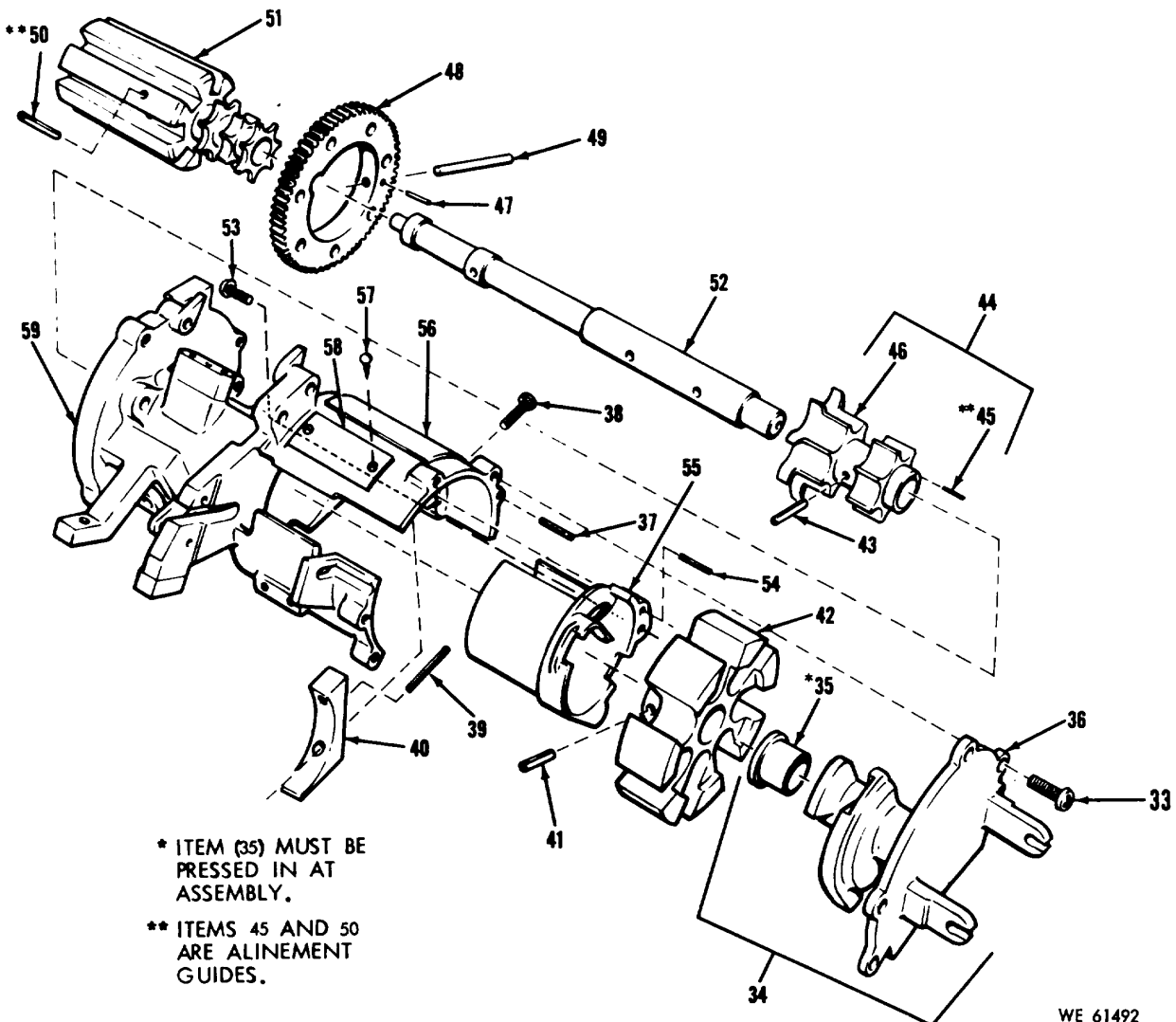

- 1-Screw
- 2-Screw
- 3-Link guide
- 4-Screw
- 5-Guide
- 6-Pin
- 7-Screw
- 8-Nose guide
- 9-Pin
- 10-Link
- 11-Pin
- 12-Pin
- 13-Arm
- 14-Nut
- 15-Screw
- 16-Screw
- 17-Feed solenoid
- 18-Screw
- 19-Spring
- 20-Clearing guide

- 21-Pin
- 22-Screw
- 23-Insert
- 24-Screw
- 25-Housing
- 26-Bearing
- 27-Roller
- 28-Push rod assembly
- 29-Pin
- 30-Button
- 31-Spring
- 32-Pin
- 33-Screw
- 34-Forward guide plate assembly
- 35-Bearing
- 36-Forward guide plate
- 37-Pin
- 38-Screw
- 39-Pin
- 40-Feeder

- 41-Pin
- 42-Sprocket
- 43-Pin
- 44-Stripper sleeve assembly
- 45-Pin
- 46-Strippersleeve
- 47-Pin
- 48-Gear
- 49-Pin
- 50-Pin
- 51-Push rod guide assembly
- 52-Shaft
- 53-Screw
- 54-Pin
- 55-Cam guide
- 56-Instruction plate
- 57-Drive screw
- 58-Identification plate
- 59-Housing

Figure 3-4. Delinking feeder MAU-56/A—exploded view (sheet 3 of 3).

3-6. Cleaning, Inspection, and Repair

- a. *Cleaning.* Refer to paragraph 2-9.
- b. *Inspection.* Check for worn bearings; check all parts for galling chipping, and metal transfer, check for

bent or sheared spring pins and aligning pins.

- c. *Repair.* Refer to general repair instructions for mechanical components (para 2-7).

Section IV. GUN ELECTRIC DRIVE ASSEMBLY

3-7. Description

The gun electric drive assembly consists of two major components, the gun drive control assembly and the electric drive assembly. The gun drive control assembly, which controls gun speed, is replaceable at organizational level. Refer to TM 91005-298-12. The electric drive assembly consisting of a 28-volt DC motor and a gear housing, requires further disassembly and assembly as shown in figures 3-5 and 3-6.

Caution: The motor and the gear housing are matched assemblies having identical serial numbers. Do not interchange nonmatching units. Disassembly of the motor, other than as shown, is not recommended. The motor housing, end bells, and armature are matched and electrically aligned by the manufacturer.

3-8. Disassembly

Refer to TM 9-1005-298-12 for information regarding removal of the gun drive control assembly from the electric drive assembly. Disassemble the electric drive assembly as shown in figure 3-5 and in the sequence of item numbers in figure 3-6. Observe the following special requirements.

- a. When disassembling the gearing from the gear housing (3, fig. 3-6), it will be necessary to drill a hole (approx 1/8-inch diameter) in retaining cap (4). Pry the cap out with a small punch or similar tool. Discard the damaged cap.

- b. Make note of the number of shims (17) used under the ball bearing (16) on end of shaft (9).

Caution: Do not remove needle bearings from gear housing unless in-place inspection reveals a fault. Damage can be caused by removal. Refer to table 3-1.

3-9. Cleaning, Inspection, and Repair

- a. *Cleaning.* Clean needle bearings, gears, shafts, and gear housing with solvent (SD or TPM).

Caution: Do not immerse sealed ball bearings or the motor assembly in solvent. Wipe ball bearings with a clean cloth and use an air pressure nozzle to blow carbon brush dust out of motor.

- b. *Inspection.* Refer to table 3-1.
- c. *Repair.* Repairs are limited to replacement of parts provisioned; refer to TM 9-1005-298-35P. Observe the following repair requirements.

(1) Replace all needle bearings that are removed. These bearings are sized to the mating shaft by being pressed into the gear housing and are usually damaged by removal.

(2) Replace brush springs (fig. 3-5) whenever brushes are replaced. Springs may have lost temper and strength though no visible fault exists.

(3) Observe Caution in paragraph 3-7 against interchange or replacement of matched components.

Table 3-1. Electric Drive Assembly Inspection Points

Component	Figure and item	Inspection for
All gears	3-6, 7, 10, 12, 14	Chipped or broken teeth and evidence of galling, metal transfer, or excessive wear. (Wear through the black phosphate coating is normal.)
Needle bearings	3-6 21, 21, 23	Radial play on shaft prior to shaft removal. Evidence of bearing roughness when mating shaft is turned. (Bearings are sized for correct shaft fit when pressed into the gear housing and may be oversize or damaged when removed.)
Ball bearings	3-6, 18, 20	Axial (end) play between inner and outer races. Evidence of roughness felt when the bearing is turned.
Shafts	3-6 6, 9	Breaks, galling, or evidence of ball bearing rotation on shaft.
Armature	3-5	(Visually through brush access openings.) Pitting, scoring, or excessive wear of commutators. Evidence of over-

Component	Figure and item	Inspection for
Motor housing	3-5	heating such as thrown solder at commutator segment connections or blackened commutators. (Normal color is copper/brown.)
Brush holders	3-5	External damage. All visible wiring for breaks, worn insulation, or loose terminals
Brushes	3-5	(Visually through brush access openings.) Breaks, bends, stripped screw threads, or looseness in endbells (epoxy retaining material chipped out.)
Brush springs	3-5	Breaks, chipping, loose wire or terminal, and excessive wear (0.25-inch min. length from shoulder to face). Breaks and deformation.

3-10. Assembly

Assemble the electric drive assembly as shown in figure 3-5 and in essentially the reverse of item number sequence shown on figure 3-6. Observe the following special requirements:

a. When installing new brush springs, note that the springs are shaped at one end to fit tightly and be retained on the guide pins in the brush covers.

b. Press in new needle bearings flush with respective inside shoulders of the gear housing. Coat the rollers of these bearings with grease (GIA). Assemble shafts, gears and ball bearings as shown in sectional view on figure 3-5. Apply grease (GIA) on gear teeth but do not "pack" the gear housing.

c. When installing the gear housing assembly on the motor forward end bell, use the same number of shims under the output shaft bearing as were removed during disassembly. Check the shaft for 0.003 to 0.008-inch end play. Remove the gear housing, add or remove shims, and reinstall gear housing if required.

3-11. Gun Electric Drive Assembly Testing

The electric gun drive assembly may be tested for proper operation by installing it on the subsystem as follows:

Note Extensive running for wear-in of replacement parts is not required.

a. Install gun drive control assembly on the electric drive assembly and install the assembly on a mounted gun. Refer to TM 9-1005-298-12 for procedure.

Warning: Be sure there is no ammunition present in any subsystem component before operating the gun drive motor.

b. Follow the procedure for operational check with power on (TM 9-100-212) except as follows:

(1) Operate the gun at low speed (first trigger detent) for three 3-second bursts. Observe gun barrel rotation.

Caution: High speed operation of the gun should be limited to momentary bursts. Gun may be damaged by over-speeding when operated without ammunition.

(2) Check operation at high speed by pressing the trigger to the first detent, then momentarily to the second detent. Observe that gun barrel rotational speed increases.

c. Follow the steps of operational check procedure (TM 9-1005-29812) required to safe the subsystem and remove all electrical power.

d. Remove one brush cover and one brush from each armature commutator position. Turn the armature by rotating the gun barrels and inspect the armature for evidence of excessive arcing or overheating. Reinstall brushes and brush covers.

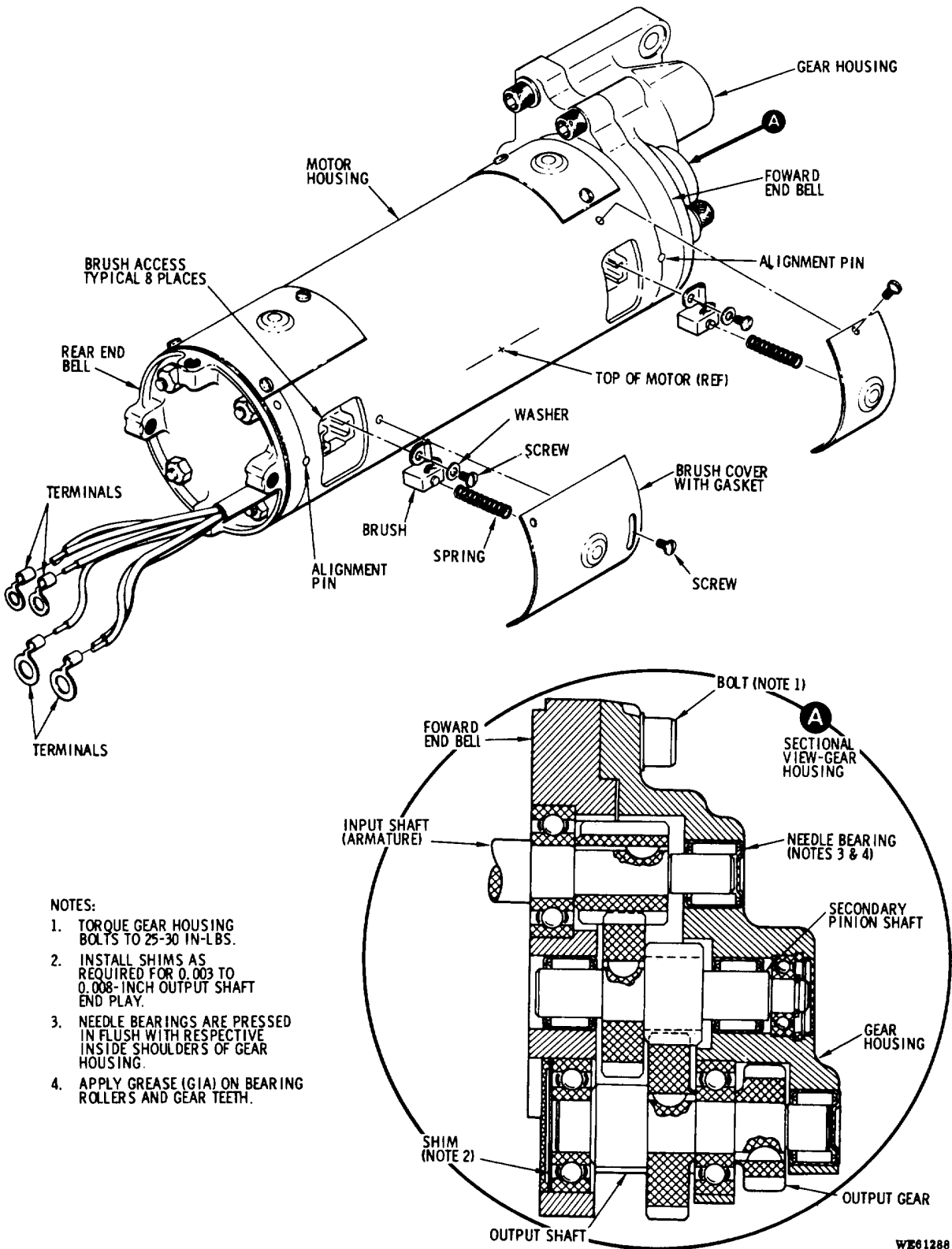

- NOTES:
1. TORQUE GEAR HOUSING BOLTS TO 25-30 IN-LBS.
 2. INSTALL SHIMS AS REQUIRED FOR 0.003 TO 0.008-INCH OUTPUT SHAFT END PLAY.
 3. NEEDLE BEARINGS ARE PRESSED IN FLUSH WITH RESPECTIVE INSIDE SHOULDERS OF GEAR HOUSING.
 4. APPLY GREASE (G1A) ON BEARING ROLLERS AND GEAR TEETH.

WE61288

Figure 3-5. Electric drive assembly—partially exploded view.

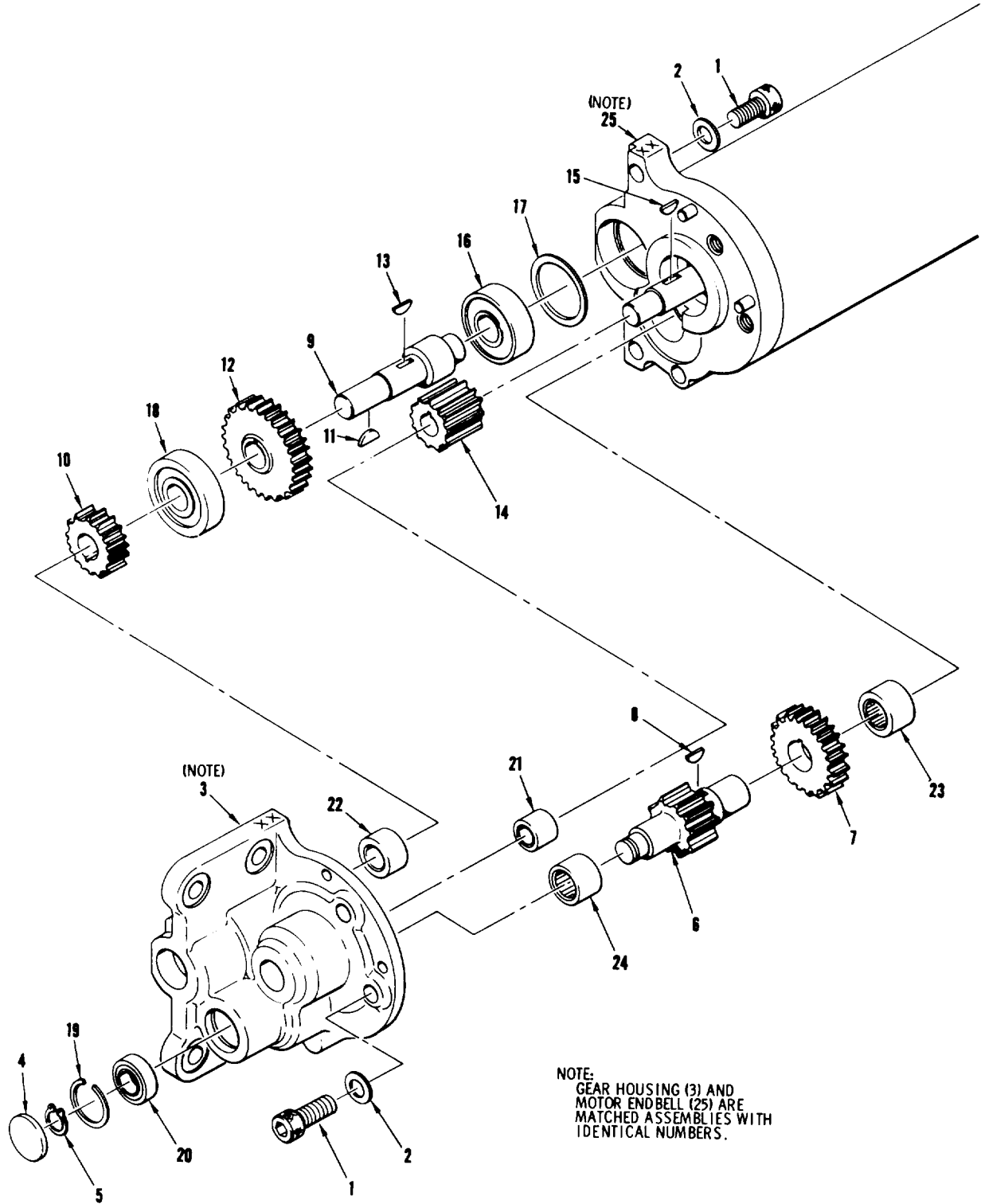

WE61287

Figure 3-6. Electric drive assembly gear housing—exploded view.

1-Bolt	10-Pinion gear	19-Snap ring (retainer)
2-Washer	11-Key	20-Ball bearing
3-Gear housing	12-Gear	21-Needle bearing
4-Retaining cap	13-Key	22-Needle bearing
5-Snap ring (retainer)	14-Pinion gear	23-Needle bearing
6-Pinion	15-Key	24-Needle bearing
7-Gear	16-Ball bearing	25-Forward end bell
8-Key	17-Shim	
9-Shaft	18-Ball bearing	

Figure 3-6—Continued.

Section V. SENSING UNIT AND CABLE ASSEMBLY

3-12. Disassembly/Assembly

See figure 3-7.

3-13. Cleaning, Inspection, and Repair

a. Cleaning. Refer to TM 9-247 for cleaning instructions.

b. Inspection. Inspect for frayed insulation, broken wires, and loose connections. Inspect connectors for

bent or broken pins and corrosion at terminals. Isolate faulty components by using troubleshooting procedures on table 2-3.

c. Repair. Repair cable in accordance with general procedures in paragraph 2-8. Refer to table on figure 3-7 and to TM 9-1005-298-35P for wire specifications and for connector and contact part numbers.

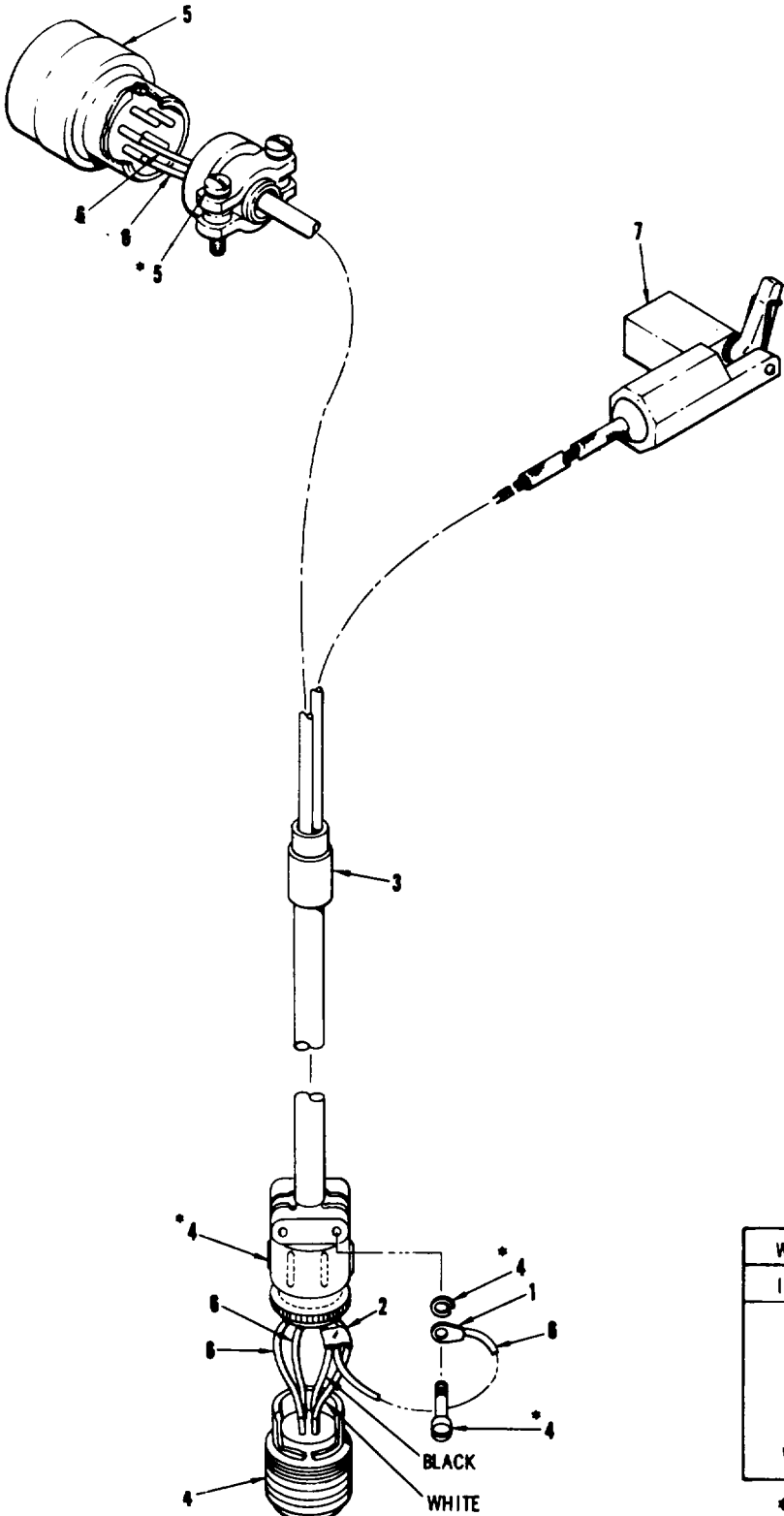

- 1. TERMINAL LUG, MS25036-1
- 2. FERRULE
- 3. CABLE MARKER BAND
- 4. CONNECTOR PLUG P5
- 5. CONNECTOR PLUG P6
- 6. WIRE, MS25190B20
- 7. SENSING UNIT ASSEMBLY

WIRE	FROM		TO	
	ITEM	PIN	ITEM	PIN
6	4	P5-4	5	P6-B
6	4	P5-1	5	P6-E
6	1	-	7	-
BLK	4	P5-3	7	-
WHT	4	P5-2	7	-

* DENOTES ITEMS ARE PART OF ASSEMBLY REPRESENTED BY NUMBER

WE 15602

Figure 3-7. Sensing unit and cable assembly.

CHAPTER 4

REPAIR OF FAIRING ASSEMBLY

4-1. Description

The fairing assembly is constructed on mat-molded fiberglass which is resin impregnated and cured while under heat and pressure. The fairing assembly is important to the operation of the armament subsystem XM27E1 since the upper fairing assembly with its ram air duct provides for accelerated ejection of cartridge links. This prevents the links from striking the aircraft during in-flight firing.

4-2. Disassembly/Assembly

See figure 4-1. Limit disassembly to removal of faulty components such as fasteners, receptacles, and decals.

4-3. Cleaning, Inspection, and Repair

a. Cleaning. Refer to paragraph 2-9a and apply procedures used for cleaning mount assembly components.

b. Inspection. Check for damaged fasteners and receptacles and for breaks and tears in the fiberglass structure.

c. Repair.

(1) Replace damaged fasteners and receptacles using standard shop procedures and tools.

(2) Repair breaks and tears in fiberglass structure as follows:

(a) Stop-drill the ends of the break or tear using a 1/8-inch (No. 30) drill.

(b) Lay out and pencil mark an area extending approximately one inch beyond all edges of the damage.

Warning: If a power sander is used, avoid breathing the fine fiberglass dust produced. This dust can cause serious skin and respiratory irritations. Wear protective clothing and use a mask.

(c) Use 280 grit sandpaper to sand the area to be patched. Sanding should be deepest at the center of the damaged area and beveled out at the edges.

(d) Clean the area to be patched with methyq-ethyl-ketone, Specification TT-M-261.

(e) Cut a fiberglass patch of appropriate size to fit into the beveled area to be patched. Fray all edges to fair in smoothly.

(f) Mix resin and catalyst in the proportions recommended on the manufacturer's instruction sheet.

(g) Apply a coat of the resin to the area to be patched, place fiberglass patch in position and apply a heavy second coat of resin to the top of the patch. The top coat of resin should extend sufficiently beyond the edges of the patch to assure a smooth feathered edge.

(h) Tape a piece of cellophane over the patch and extending 2 or 3 inches beyond the patch edges.

(i) Gently work out all air bubbles and shape the top coat of resin to fair in smoothly with the contours of the fairing.

(j) Subject the patch to curing heat for the time specified by the manufacturer's instructions.

(k) Remove cellophane, sand patch lightly, then paint and replace any damaged decals (TM 9-213).

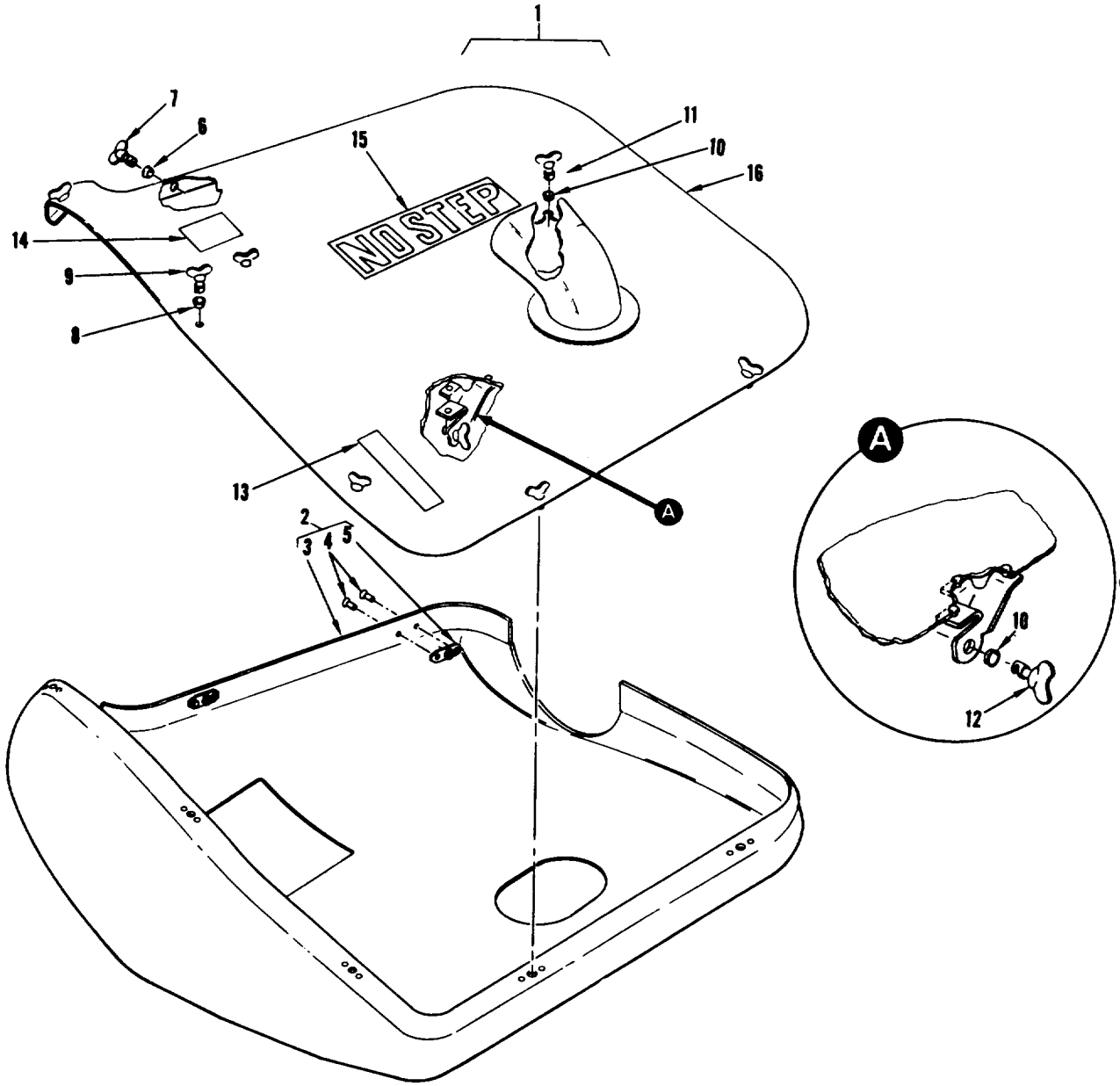

- 1. UPPER FAIRING ASSY
- 2. LOWER FAIRING ASSY
- 3. LOWER FAIRING
- 4. RIVET
- 5. RECEPTACLE
- 6. RETAINER
- 7. TURNLOCK STUD
- 8. RETAINER
- 9. TURNLOCK STUD
- 10. RETAINER
- 11. TURNLOCK STUD
- 12. TURNLOCK STUD
- 13. CAUTION DECAL
- 14. IDENTIFICATION DECAL
- 15. NO STEP DECAL
- 16. UPPER FAIRING

WE 15603A

Figure 4-1. Fairing assembly—exploded view.

CHAPTER 5

REPAIR OF MOUNT ASSEMBLY

Section I. MOUNT ASSEMBLY

5-1. Disassembly/Assembly

Major components of the mount assembly are disassembled and assembled as shown in figure 5-1.

5-2. Door Filler Assembly

Replaceable components of the flexible plastic door filler assembly are shown on figure 5-2. No special

maintenance information is required.

5-3. Control Rod Assembly

The control rod assembly is maintained at organizational level and all replacement parts are provisioned at that level. Refer to TM 9-1005-298-12.

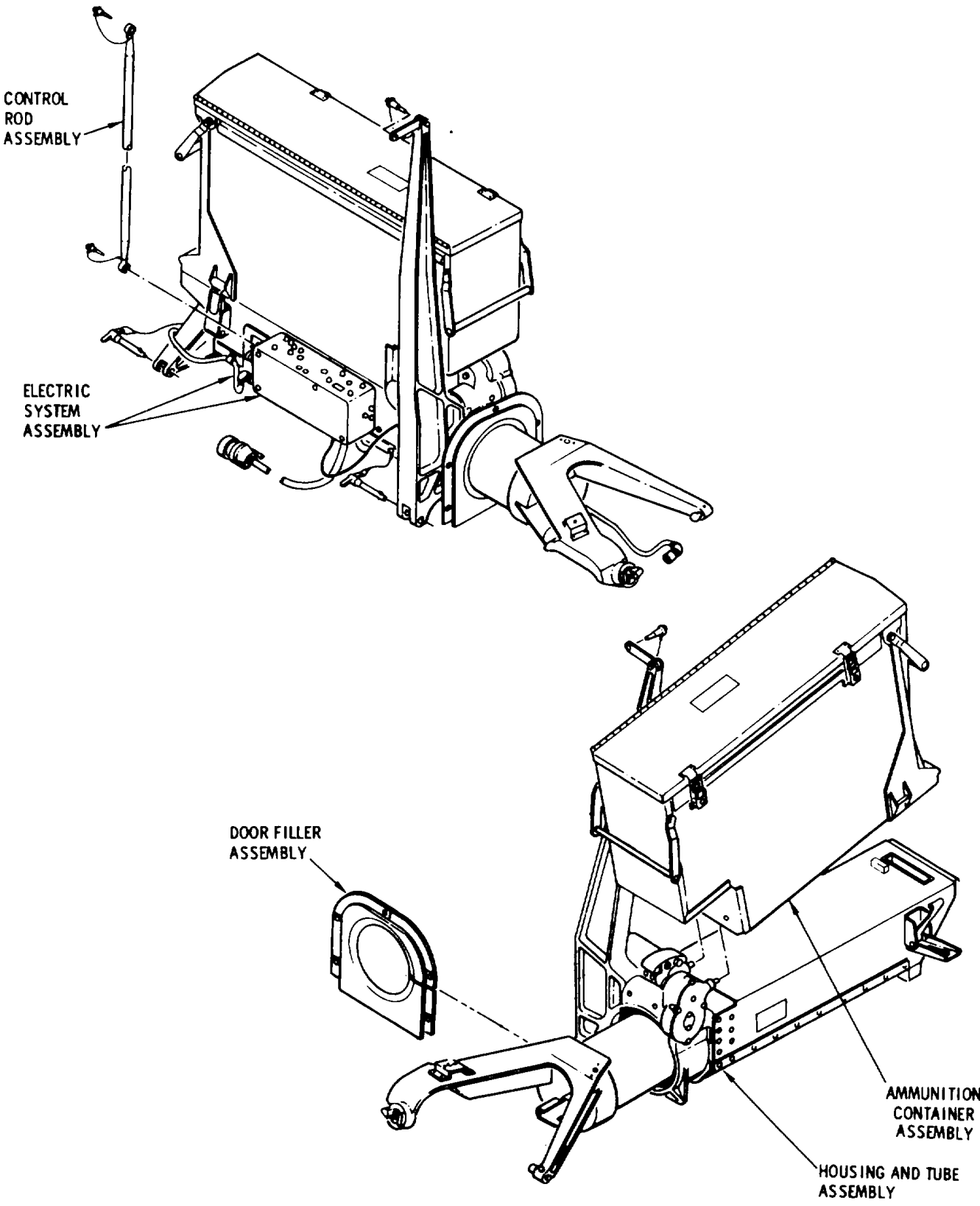

Figure 5-1. Mount assembly—exploded view.

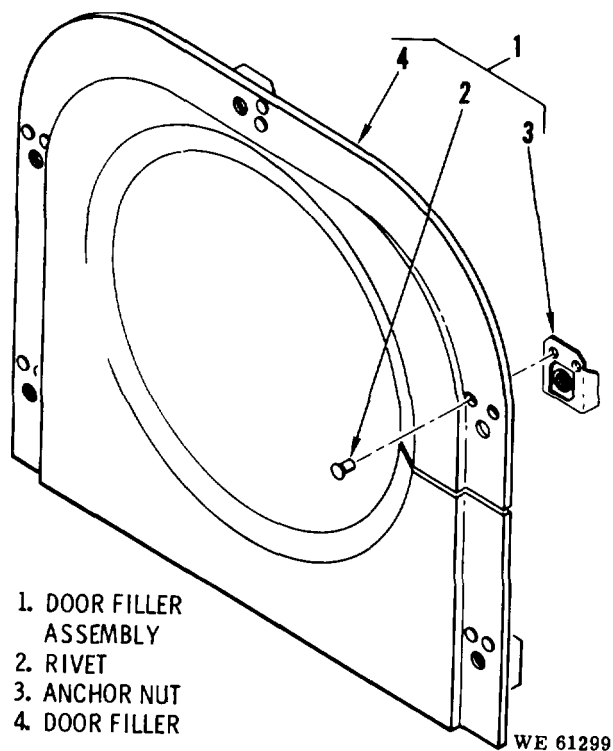

Figure 5-2. Door filler assembly—exploded view.

Section II. AMMUNITION

5-4. Disassembly/Assembly

Disassemble the ammunition container assembly as required for replacement of worn or damaged parts in the order of item numbers on figure 5-3. Reassemble in reverse of item number order.

5-5. Cleaning, Inspection, and Repair

a. Cleaning. Refer to paragraph 2-9a for general cleaning instructions.

b. Inspection.

(1) Check for worn or damaged roller assemblies (31, fig. 5-3).

(2) Check box cover, handles (3), and levelers (23), for breaks and bends.

(3) Check levelers for broken springs (22).

(4) Check box structure for dents and breaks.

c. Repair. Repair by replacing worn or damaged parts and by straightening dents and bends when feasible.

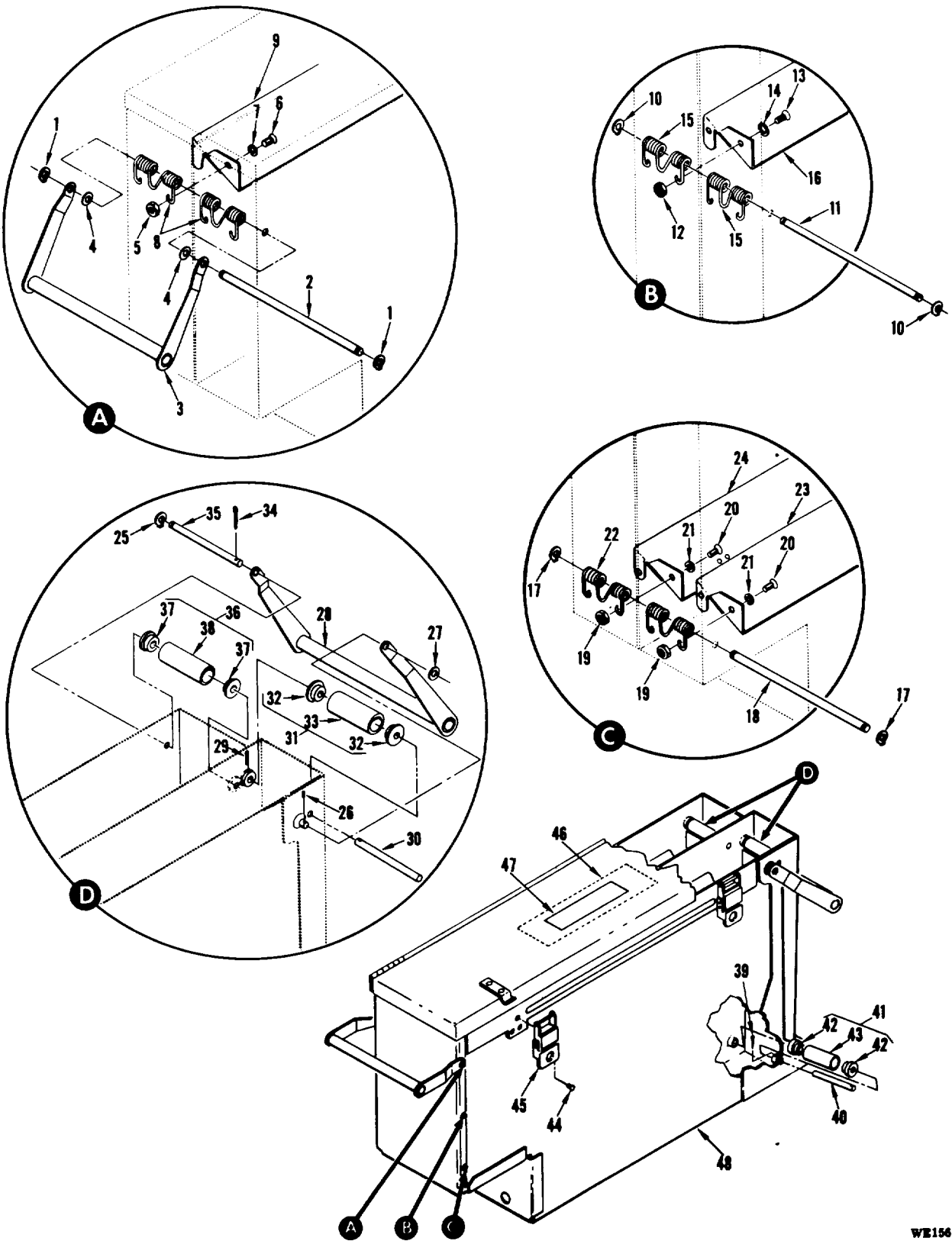

Figure 5-3. Ammunition container assembly—exploded view.

1-Retaining ring	17-Retaining ring	33-Sleeve spacer
2-Pin	18-Pin	34-Cotter pin
3-Handle	19-Nut	35-Pin
4-Flatwasher	20-Machine screw	36-Roller assembly
5-Nut	21-Flat washer	37-Sleeve bearing
6-Machine screw	22-Spring	38-Sleeve spacer
7-Flat washer	23-Leveler	39-Cotter pin
8-Spring	24-Leveler assembly	40-Pin
9-Leveler	25-Retaining ring	41-Roller assembly
10-Retaining ring	26-Spring pin	42-Sleeve bearing
11-Pin	27-Flat washer	43-Sleeve spacer
12-Nut	28-Handle	44-Rivet
13-Machine screw	29-Cotter pin	45-Rim latch
14-Flat washer	30-Pin	46-Loading decal
15-Spring	31-Roller assembly	47-Caution decal
16-Leveler	32-Sleeve bearing	48-Ammunition container

Figure 5-3—Continued.

Section III. ELECTRICAL SYSTEM ASSEMBLY

5-6. Disassembly/Assembly

The electrical system is disassembled and reassembled as shown on figure 5-4.

a. Control Box Subassembly. The control box subassembly is disassembled and assembled as shown in figure 5-5.

b. Special Purpose Branched Cable. The special purpose branched cable is disassembled and assembled as shown in figure 5-6.

5-7. Cleaning, Inspection, and Repair

a. Cleaning. Electrical system components normally will not require cleaning. Solvent or cleaning fluids should not be used due to possibility of damage to insulation or impairment of electrical continuity. Wipe out

any foreign matter with a clean cloth or blow out using an air pressure nozzle.

b. Inspection. Inspect electrical system for frayed insulation, broken wires, and loose connections. Inspect connectors for bent or broken pins and corrosion at terminals. Isolate faulty components by using troubleshooting procedures of table 2-3.

c. Repair. No repair of components within the control box is feasible. Replace those found faulty. Repair wiring and cables in accordance with general procedures in paragraph 2-8. Refer to TM 9-1005-29835P and to wire list tables for wire specifications and for connector and contact part numbers.

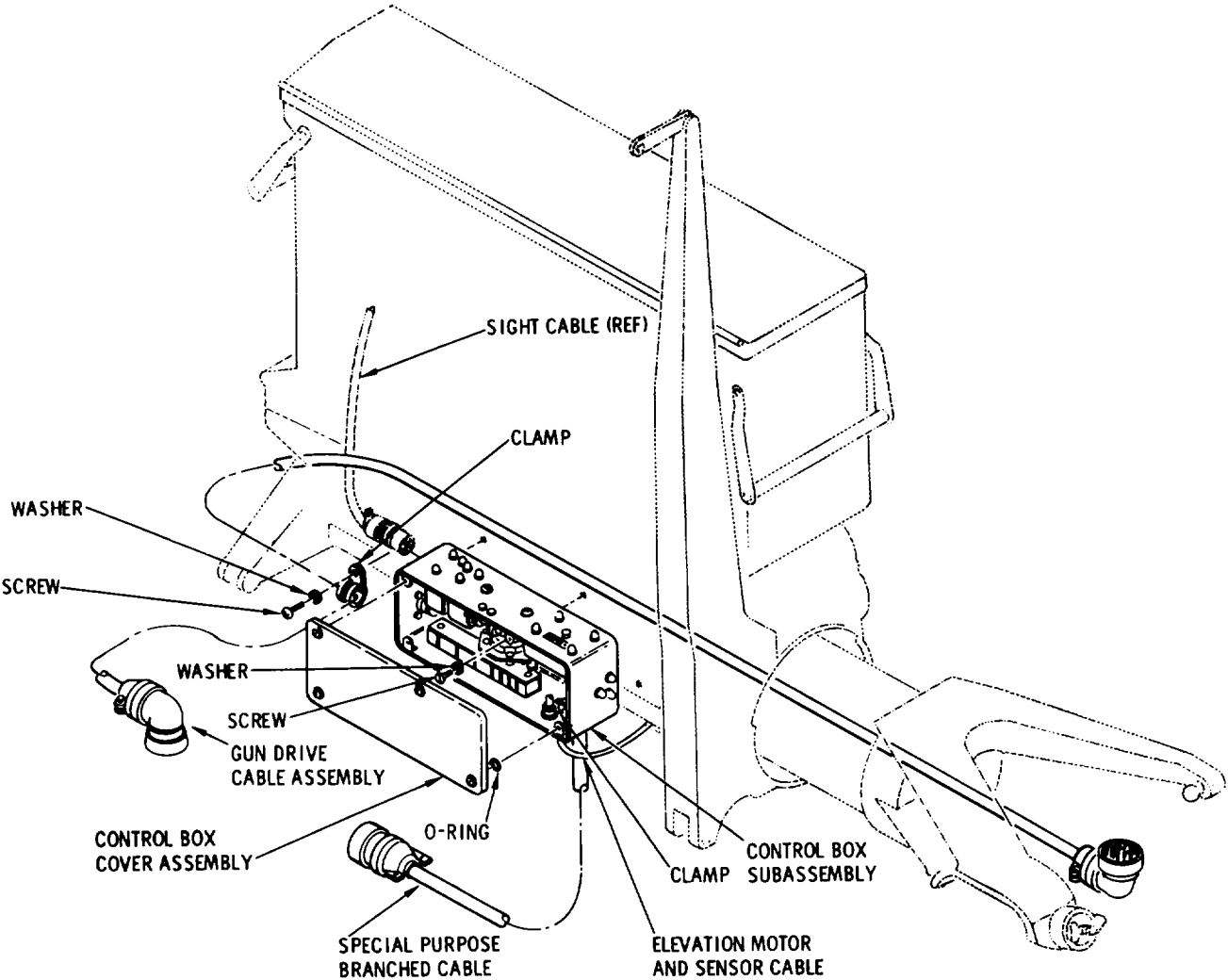

WE 61290

Figure 5-4. Electrical system assembly.

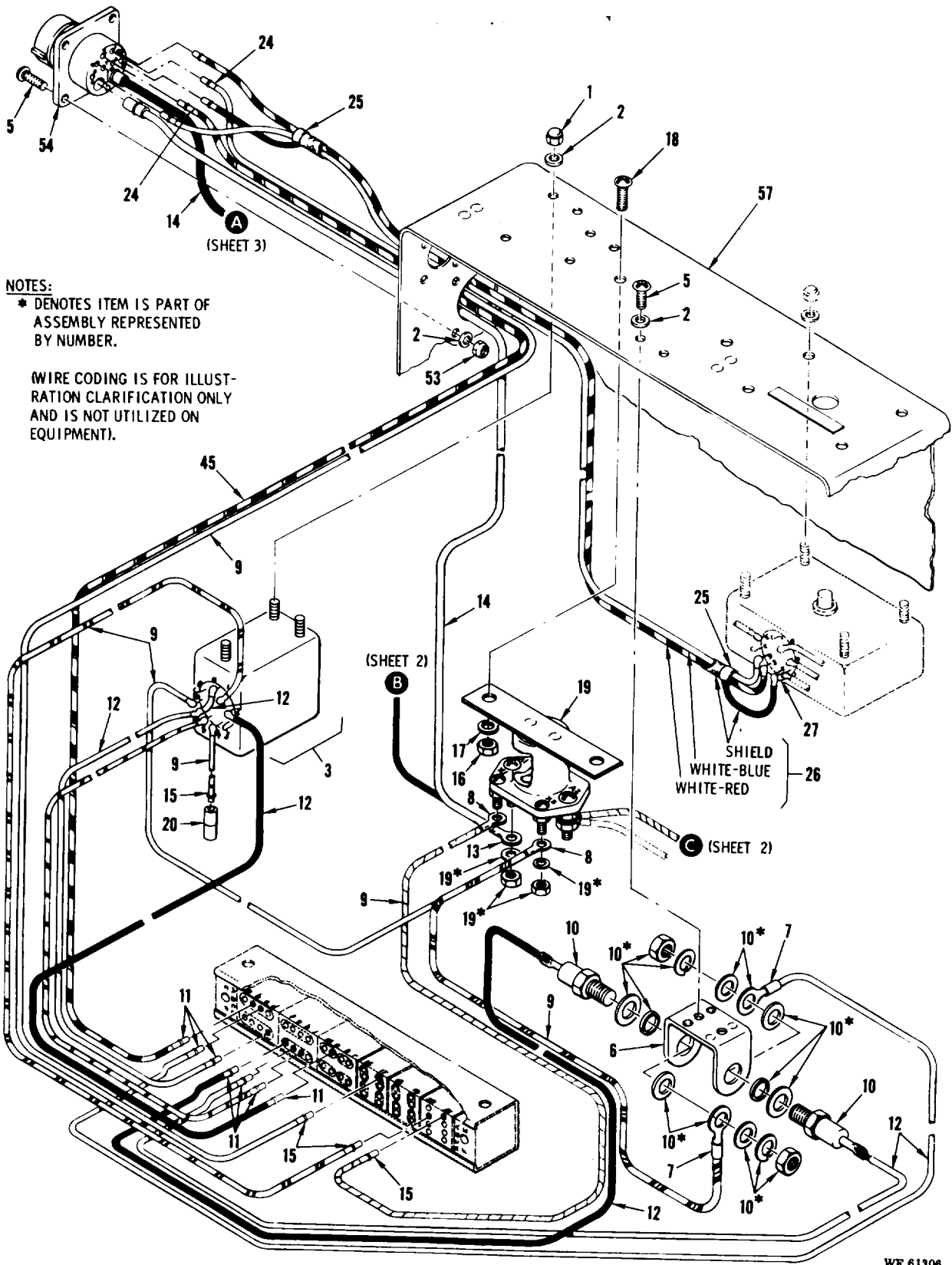

NOTES:
* DENOTES ITEM IS PART OF ASSEMBLY REPRESENTED BY NUMBER.
WIRE CODING IS FOR ILLUSTRATION CLARIFICATION ONLY AND IS NOT UTILIZED ON EQUIPMENT).

WE 61306

Figure 5-5 (1). Control box subassembly—partial exploded view (sheet 1 of 3).

- | | | |
|-----------------------------|-----------------------------|----------------------------|
| 1-Nut | 20-Splice, 11697579 | 39-Cable assembly |
| 2-Washer | 21-Nut | 40-Grommet |
| 3-Relay assembly M1 | 22-Washer | 41-Screw |
| 4-Relay assembly M2 | 23-Relay assembly | 42-Terminal lug, MS20659-7 |
| 5-Screw | 24 Contact, 11697840 | 43-Terminal lug, MS25036-8 |
| 6-Bracket assembly | 25-Sleeving | 44-Terminal lug, MS25036-3 |
| 7-Insulation | 26-Wire, AWG22, MIL-C-7078 | 45-Wire, MS25190B18 |
| 8-Terminal lug, MS25036-1 | 27-Wire, QQ-W-343 | 46-Screw |
| 9-Wire MS25190B20 | 28-Logic module Z1 | 47-Terminal box |
| 10-Diodes, CR1 and CR2 | 29-Insulation | 48-Module (part of TB1) |
| 11-Contact 11697831 | 30-Relay assembly K2 and K3 | 49-Module (part of TB1) |
| 12-Wire, MS25190B16 | 31-Nut | 50-Module (part of TB1) |
| 13-Terminal lug, MS25036-15 | 32-Washer | 51-Module (part of TB1) |
| 14-Wire, MS25190B18 | 33-Screw | 52-Identification plate |
| 15-Contact, 11697830 | 34-Loop clamp | 53-Nut |
| 16-Nut | 35-Loop clamp | 54-Connector receptacle J2 |
| 17-Washer | 36-Screw | 55-Receptacle assembly J3 |
| 18-Screw | 37-Bracket | 56-Connector |
| 19-Relay K1 | 38-Grommet | 57-Control box |

Figure 5-5-Continued.

Table 5-1. Wire List for Figure 5-5

Wire	From			To		
Item	Item	Pin	Terminal	Item	Pin	Terminal
9	54	J2-1	24	49	TB1-A17	15
45	54	J2-2	24	51	TB1-Eb	11
14	54	J2-10	42	41	GRD	42
14	54	J2-11	13	19	K1-A1	10
9	10	CR1-2	10	19	K1-X2	10
12	19	CR2-2	10	51	TB1-Ec	11
9	19	K1-X1	8	48	TB1-A21	15
12	41	GRD	44	50	TB1-Fm	11
12	41	GRD	43	48	TB1-A20	15
9	56	J3-1	*	49	TB1-D16	15
9	56	J3-2	*	48	TB1-C20	15
9	56	J3-3	*	19	K1-A1	45
9	8	M1-1	*	48	TB1-B20	15
9	8	M1-1	*	20	TB2	20
9	8	M1-5	*	51	TB1-Fh	11
9	3	M1-7	*	19	K1-X2	8
12	8	M1-6	*	3	M1-9	*
12	8	M1-9	*	51	TB1-Fd	11
12	3	M1-2	*	50	TB1-En	11
9	4	M2-1	*	48	TB1-D20	15
9	4	M2-2	*	49	TB1-B17	15
9	4	M2-5	*	19	K1-A2	44
9	4	M2-6	*	49	TB1-16	15
9	4	M2-9	*	49	TB1-B18	15
9	4	M2-4	*	51	TB1-Fc	11
9	4	M2-8	*	51	TB1-Fj	15
12	10	CR1-1	*	51	TB1-Ff	11
12	10	CR2-1	*	51	TB1-Fg	11
9	28	Z1-1	*	48	TB1-B21	15
9	28	Z1-9	*	61	TB1-Fa	11
9	28	Z1-6	*	61	TB1-Ea	11
9	28	Z1-8	*	49	TB1-D17	11
9	28	Z1-2	*	54	J2-5	*
27	28	Z1-2	*	28	Z1-1	*
26	28	Z1-4	*	54	J2-4	24

*Solder connection

Table 5-1. Wire List for Figure 5-5

Wire	From			To		
Item	Item	Pin	Terminal	Item	Pin	Terminal
26	28	Z1-3	*	54	J-3	24
9	54	J2-5	*	25	SHLD	*
9	30	K2-X1	*	49	TB1-D18	15
9	30	K2-X1	*	48	TB1-D21	15
12	30	K2-A2	*	50	TB1-Fr	11
12	39	K2-D2	*	51	TB1-Ej	15
9	30	K3-X1	*	49	TB1-D19	15
9	30	K3-X2	*	48	TB1-C21	15
9	30	K3-X2	*	50	TB1-Er	11
12	30	K3-D2	*	51	TB1-Ef	11

*Soldered connection

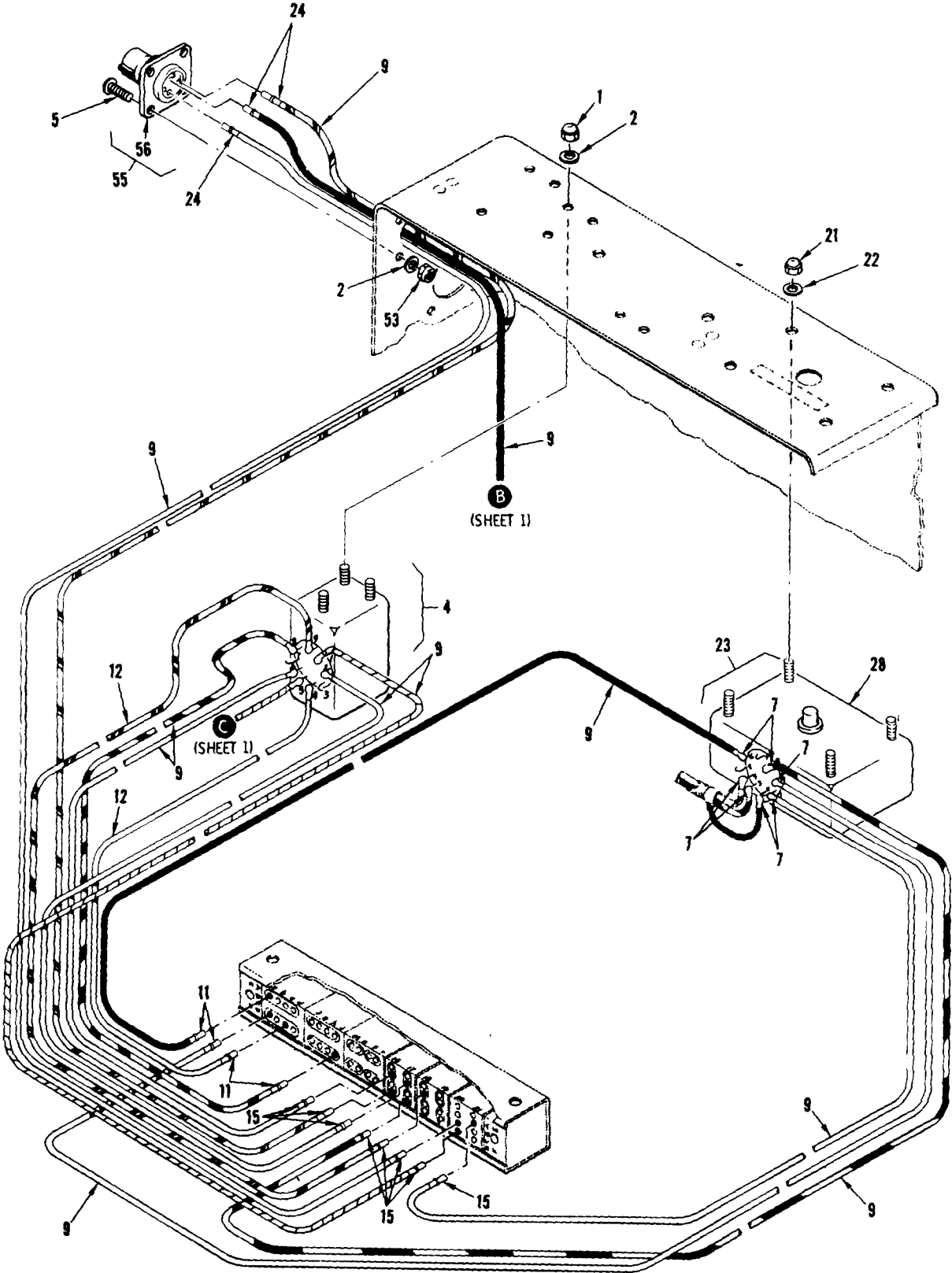

WE 61309

Figure 5-5 (2). Control box subassembly—partial exploded view (sheet 2 of 3).

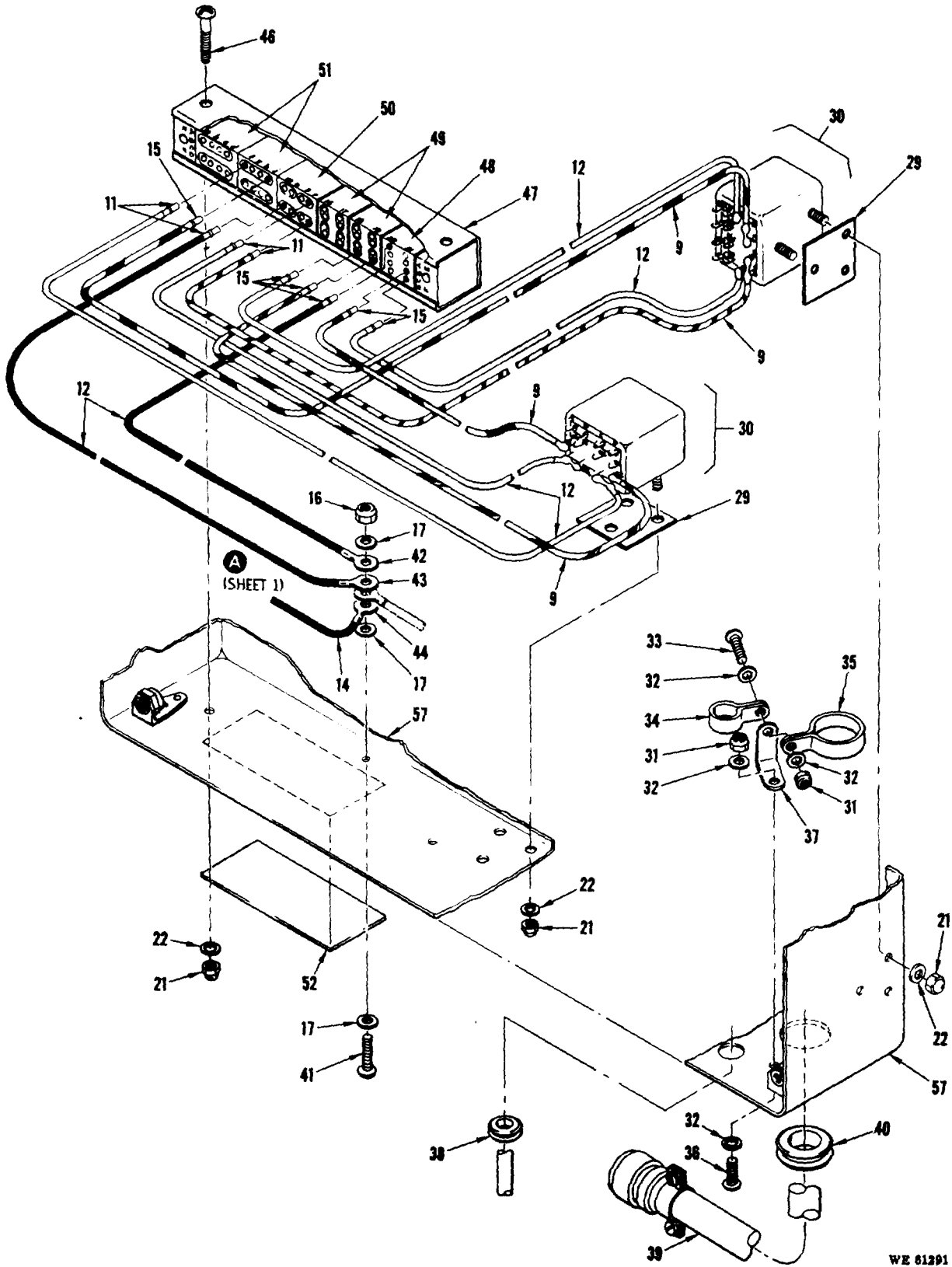
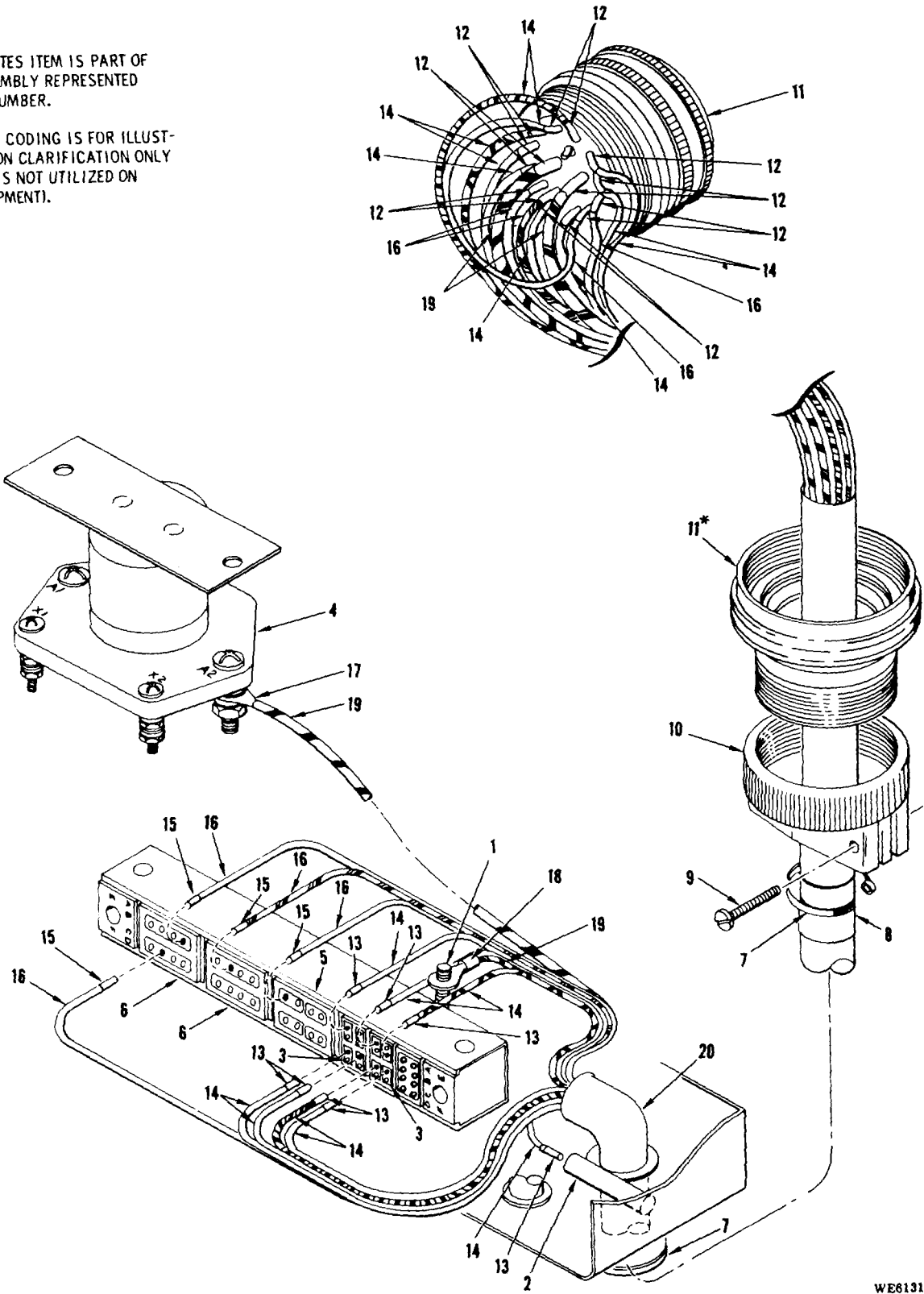

Figure 5-5 (3). Control box subassembly partially exploded view (sheet 3 of 3).

NOTES:

* DENOTES ITEM IS PART OF ASSEMBLY REPRESENTED BY NUMBER.

(WIRE CODING IS FOR ILLUSTRATION CLARIFICATION ONLY AND IS NOT UTILIZED ON EQUIPMENT).



WE81310

Figure 5-6. Special purpose branched cable assembly.

- 1-Screw
- 2-Splice, 11697579
- 3-Module (part of TB1)
- 4-Relay, K1
- 5-Module (part of TB1)
- 6-Module (part of TB1)
- 7-Cable marker
- 8-Cable marker
- 9-Screw
- 10-Connector damp

- 11-Connector plug P4
- 12-Insulation
- 13-Contact 11697830
- 14-Wire, MS25190A20
- 15-Contact, 11697831
- 16-Wire, MS25190A16
- 17-Terminal lug, MS25036-15
- 18-Terminal lug, MS20669-7
- 19-Wire, MS25190B8
- 20-Tubing

Figure 5-6—Continued.

Table 5-2. Wire List for Figure 5-6

Wire		From		To		
Item	Item	Pin	Terminal	Item	Pin	Terminal
14	11	P4-C	*	11	P4-L	13
14	11	P4-D	*	3	TB1-B19	13
14	11	P4-E	*	3	TB1-C17	13
14	11	P4-F	*	2	---	13
14	11	P4-J	*	3	TB1-C16	13
14	11	P4-K	*	3	TB1-A18	13
14	11	P4-N	*	3	TB1-A16	13
14	11	P4-P	*	3	TB1-C19	13
14	11	P4-R	*	3	TB1-C18	13
16	11	P4-H	*	5	TB1-Em	15
16	11	P4-L	*	6	TB1-Fb	15
16	11	P4-M	*	6	TR1-Eg	15
16	11	P4-T	*	6	TB1-Ed	15
19	11	P4-A	*	4	K1-A2	17
20	11	P4-B	*	1	GRD	18

*Soldered connection

Section IV. HOUSING AND TUBE ASSEMBLY

5-8. Disassembly/Assembly

Disassemble the housing and tube assembly in the sequence of item numbers shown in figures 5-7 and 5-8. Further disassembly of the elevation motor and sensor assembly and the ammunition chutes is shown on figures 5-9 and 5-10. Assembly is performed in the reverse order of the disassembly sequence. Observe adjustment and test requirements (para 5-10) during the assembly process and also make use of all applicable general repair instructions (para 2-7).

5-9. Cleaning, Inspection, and Repair

a. Cleaning. Clean in accordance with general cleaning instructions given in paragraph 2-9a.

b. Inspection.

(1) Check housing for dents, breaks, and other damage.

(2) Check bearings, shafts, and gearing for wear and damage.

(3) Check ammunition chutes for breaks, dents, and damage that could restrict flow of ammunition. Check roller and shaft in elbow chute for damage and wear.

(4) Check tube assembly components including shock isolator (11, fig. 5-8), fairing attachment bracket (14), support (16), receptacle (18), bolt ball (2), and camlock (9) for excessive wear or damage.

5-10. Assembly Adjustment and Test Requirements

The following adjustments and tests are to be performed during assembly of the worm gear and clutch and the torque tube and housing

a. Using bearing housing wrench 11697522 (fig. 5-11), screw forward bearing housing assembly (39, fig. 5-7) into mount housing until it bottoms.

b. Adjust screws in bearing housing gage 11697521 (fig. 5-11) for light friction then retract bearing housing gage into torque arm bearing. Using dowel as a lever, slide bearing housing gage up into casting as far as possible.

c. Slide forward bearing housing wrench, 11697522, through the housing and through the bearing housing gage to mate with the forward bearing housing. Turn the wrench counterclockwise to back the bearing housing outward and into contact with the bearing housing gage.

d. Lock the bearing housing in place with set screw (34, fig. 5-7). Seal the set screw with sealant, Military Specification MIL-S-22473, Grade H.

e. Remove forward bearing housing wrench. Retract bearing housing gage 11697521 and remove gages from housing assembly and secure for future use.

f. Slide worm gear (38, fig. 5-7) into housing assembly. Match polarity of worm gear (38) and gear sector on tube assembly (24), "A" end to "A" end and "B" end to "B" end. If more than one unit is being overhauled, match serial numbers of worm to gear sector.

g. Position aft bearing assembly housing (35) and key (37) on shaft assembly (36). Slide shaft assembly with key into worm gear (38) and engage forward bearing housing assembly (39). Screw aft bearing housing assembly (35) into housing assembly (46). Using bearing housing wrench (11697522, fig. 5-11) tighten aft bearing housing assembly to 125 inch-pounds torque and then back off 15 to 22.5 degrees (1 and 1 1/2 marks on wrench shaft).

h. Lock aft bearing housing assembly (35, fig. 5-7) in place with setscrew (34). Seal the set screw with sealant Military Specification MIL-S-22473, Grade H.

i. Place gear (31:) on shaft (36) and secure with retaining ring (30).

j. Lubricate all gears with grease MIL-G-23827 (GIA).

k. Proceed with assembly of torque tube assembly (24) and housing assembly (46). Apply grease MIL-G-23827 (GIA) on housing bearings. Tests to be performed during assembly are as follows:

(1) After installation of torque tube assembly (24) but prior to installation of motor and sensor assembly (12), the torque required to turn shaft (36) shall not exceed 5 inch-pounds. Use a torque wrench in the 1/4-inch square socket in the end of the shaft.

Note. If torque value exceeds 5 inch-pounds, the worm gear (38) may not be properly centered on gear sector of tube assembly (24). Recheck positioning of bearing housing assemblies (39 and 35); steps a through g above. If trouble persists, remove tube assembly (24) from housing assembly (46) and inspect bearing surfaces for dents, nicks, and burrs.

(2) Prior to installation of motor and sense assembly and with the gun or an equal weight installed in the correct position, the torque required to turn shaft (36) and shall not exceed 40 inch-pounds.

l. Proceed with installation of elevation clutch assembly (33) and elevation motor and sensor assembly (12). Coat all gear teeth with grease MIL-G-23827 (GIA).

m. When installation of elevation motor and sensor assembly (12) and gear case cover (28) is completed, and with the gun or an equal weight installed in the correct position, the torque required to turn shaft (36) shall be minimum 160 inch-pounds.

Note. If this minimum torque value is not met, clutch assembly (33) is faulty and replacement is required.

n. Install dust seal (23) on torque tube. Insert the dust seal (23) into housing assembly (49) and close all gaps between housing and seal using adhesive MIL-A-46106.

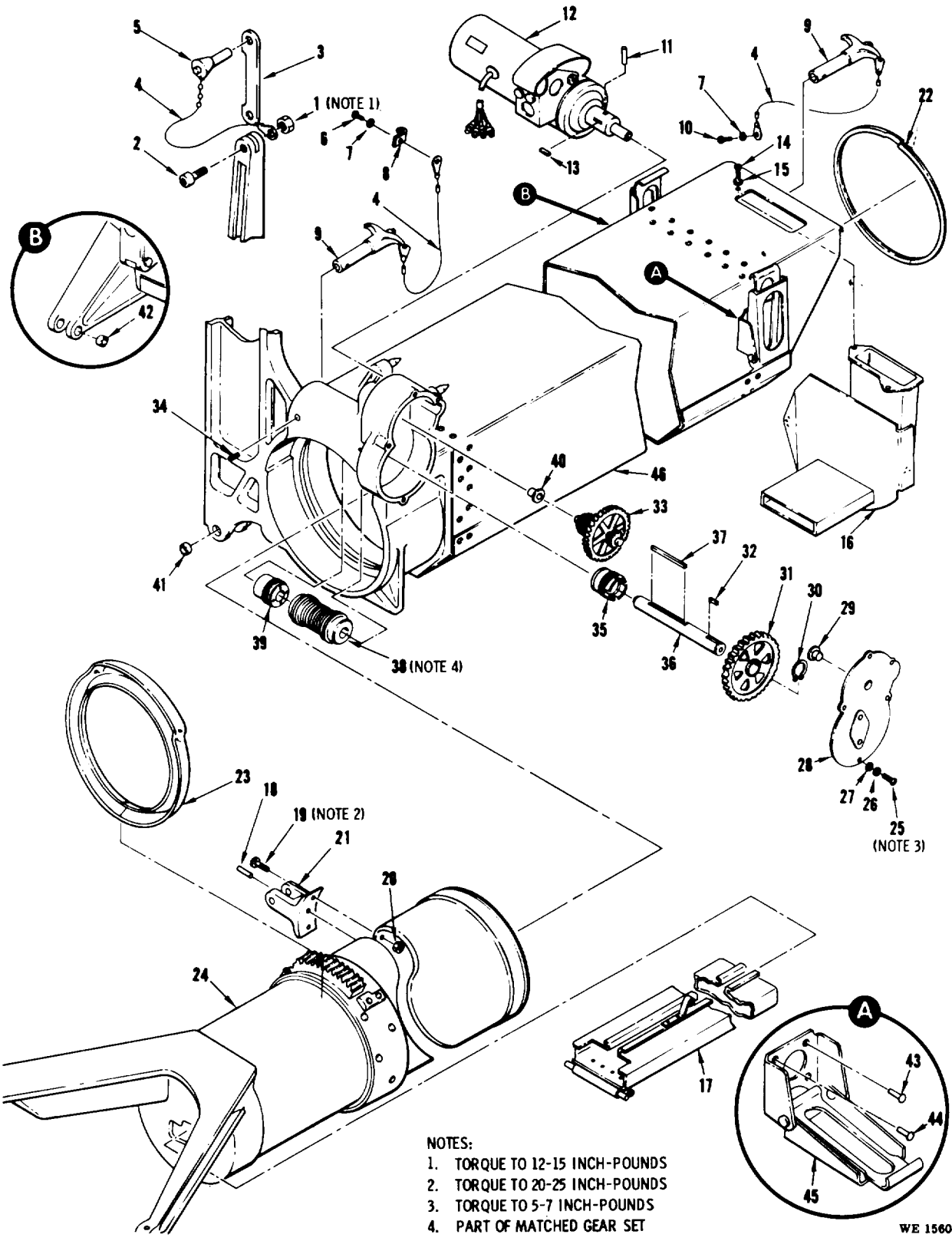
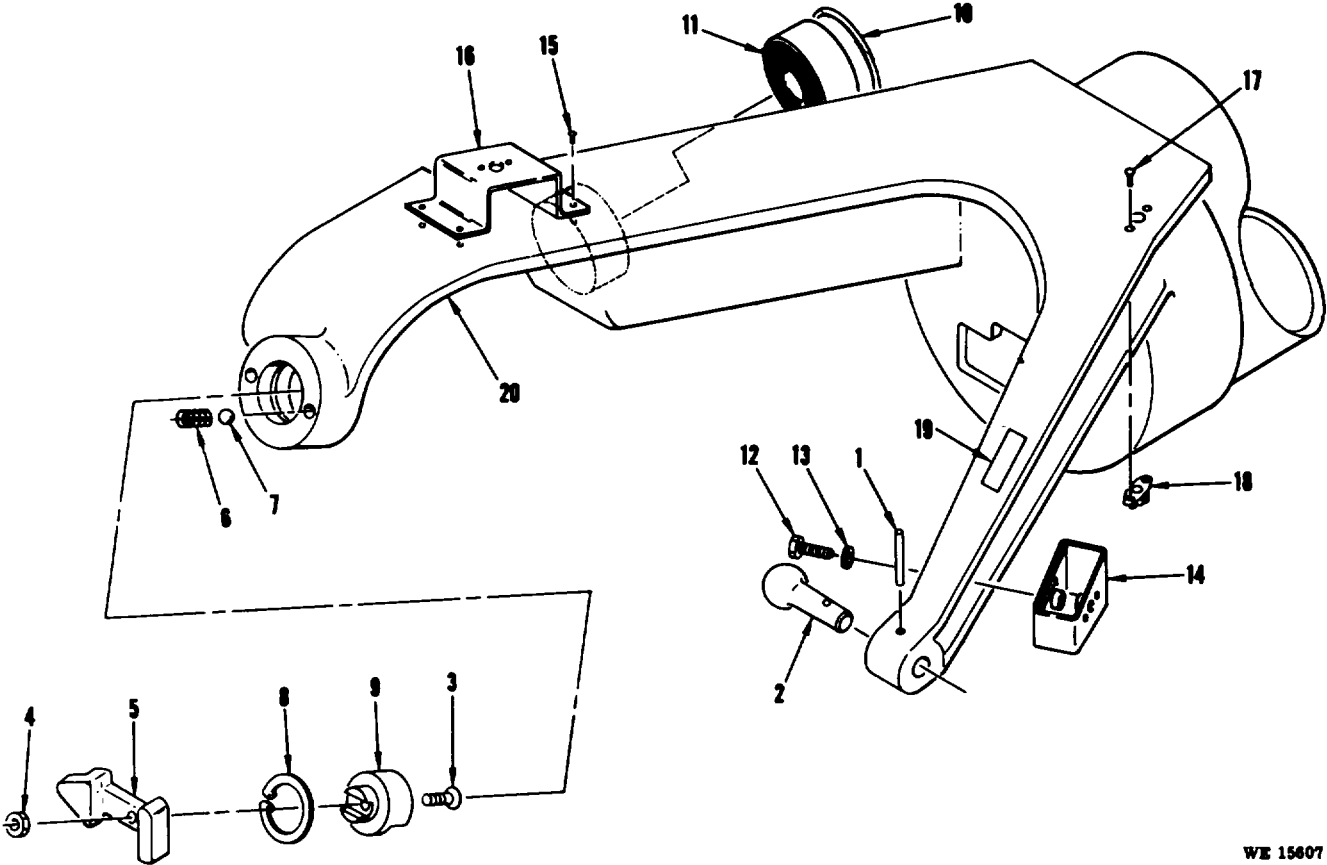

Figure 5-7. Housing and tube assembly—partially exploded view.

1-Nut	16-Adapter assembly	32-Key
2-Bolt	17-Feed chute	33-Elevation clutch assembly
3-Link	18-Locating pin	34-Set screw
4-Lanyard	19-Bolt	35-Aft bearing housing assembly
5-Release pin	20-Nut	36-Shaft
6-Screw	21-Sight drive fitting	37-Key
7-Washer	22-Retaining ring	38-Worm gear
8-Clamp	23-Dust seal	39-Forward bearing housing assembly
9-Release pin	24-Tube assembly	40-Bearing
10 -Screw	25-Screw	41-Bushing
11-Spring pin	26-Lockwasher	42-Bushing
12-Elevator motor and sensor assembly	27-Washer	43-Rivet
13-Key	28-Gear case cover	44-Rivet
14-Screw	29-Bearing	45-Latch assembly
15-Washer	30-Retaining ring	46-Housing assembly
	31-Gear	

Figure 5-7--Continued.



WE 15607

- 1—Spring pin
- 2—Bolt ball
- 3—Screw
- 4—Nut
- 5—Handle
- 6—Spring
- 7—Ball
- 8—Retaining ring
- 9—Cam lock
- 10—Retaining ring

- 11—Shock isolator
- 12—Bolt
- 13—Washer
- 14—Bracket
- 15—Rivet
- 16—Support
- 17—Rivet
- 18—Receptacle
- 19—Decal
- 20—Support assembly

Figure 5-8. Tube assembly—partially exploded view.

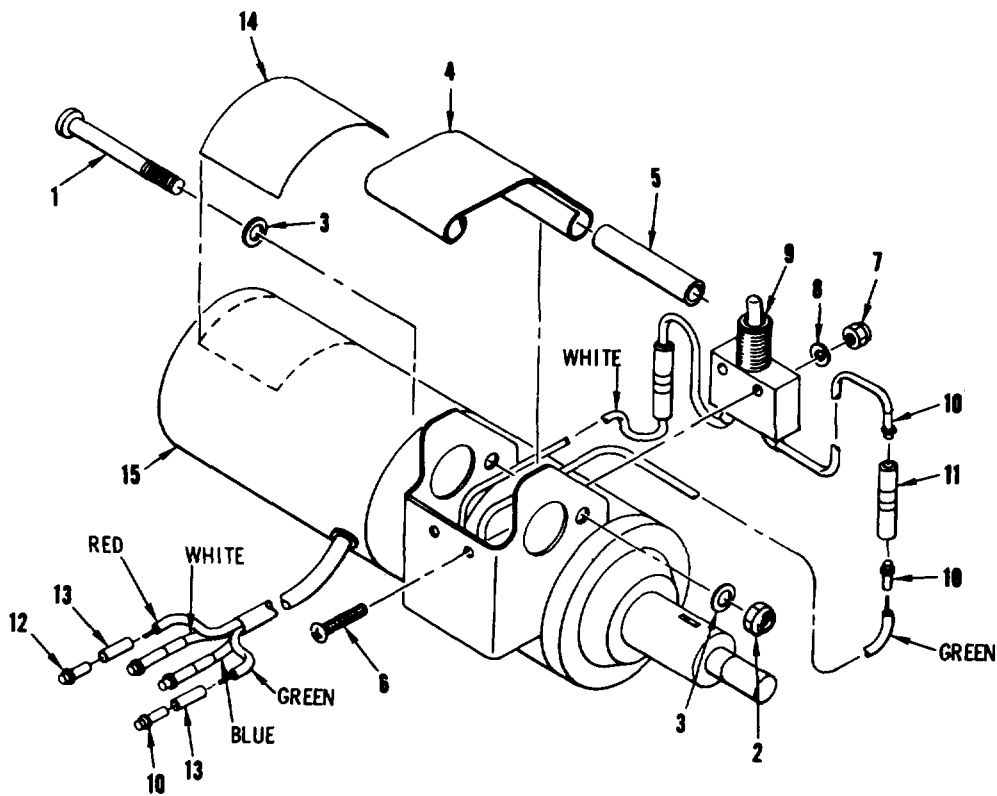

Wire	From			To		
	Item **	Item	Pin Terminal	Item	Pin	Terminal
White	9	COM	*	11	--	10
Green	9	SSG	*	11	--	10
White	11	--	10	15	--	--
Green	11	--	10	15	--	--
White	15	--	--	--	TB1 - Fn	10
Green	15	--	--	--	TB1 - A19	10
Red	15	--	--	--	TB1 - Fp	12
Blue	15	--	--	--	TB1 - Ep	10

*Soldered connection
 **Green wire is MS25190A20; others are MS25190B16

WE61320

- 1—Bolt
- 2—Nut
- 3—Washer
- 4—Switch depressor
- 5—Bushing
- 6—Screw
- 7—Nut
- 8—Washer
- 9—Switch
- 10—Contact, 11697831
- 11—Splice 11797579
- 12—Contact, 11697830
- 13—Insulating sleeve
- 14—Identification decal
- 15—Motor

Figure 5-9. Motor and sensor assembly--exploded view.

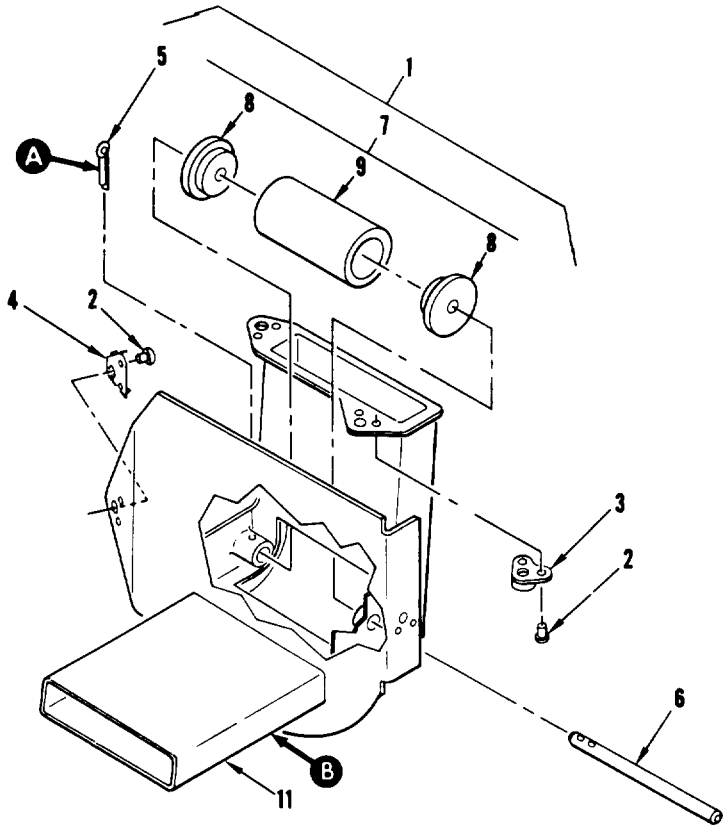
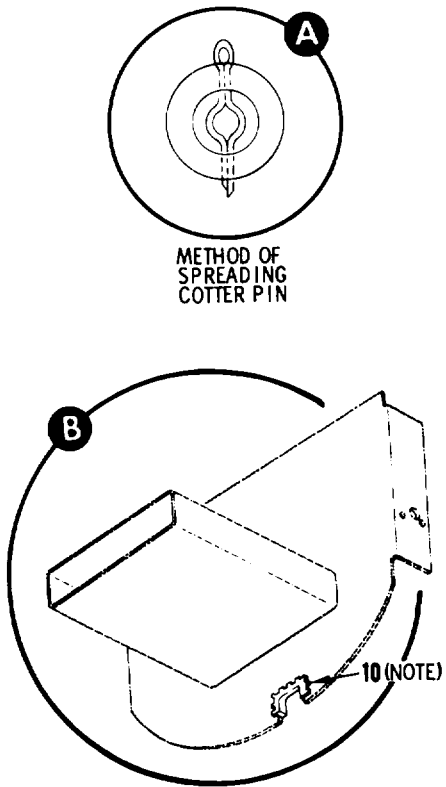

WE 15609A

NOTE: INSTALL GROMMET WITH MIL-A8623 TYPE 1 ADHESIVE

- 1—Adapter assembly
- 2—Rivet
- 3—Nut plate
- 4—Nut plate
- 5—Cotter pin
- 6—Pin

- 7—Roller
- 8—Bearing
- 9—Tube
- 10—Grommet
- 11—Elbow

Figure 5-10. Adapter assembly-exploded view.

- NOTES:
1. SEAL THREADS WITH COMPOUND MIL-S-22473, GRADE H.
2. MARKS ON WRENCH SHANK ARE 12.5 DEGREES APART.

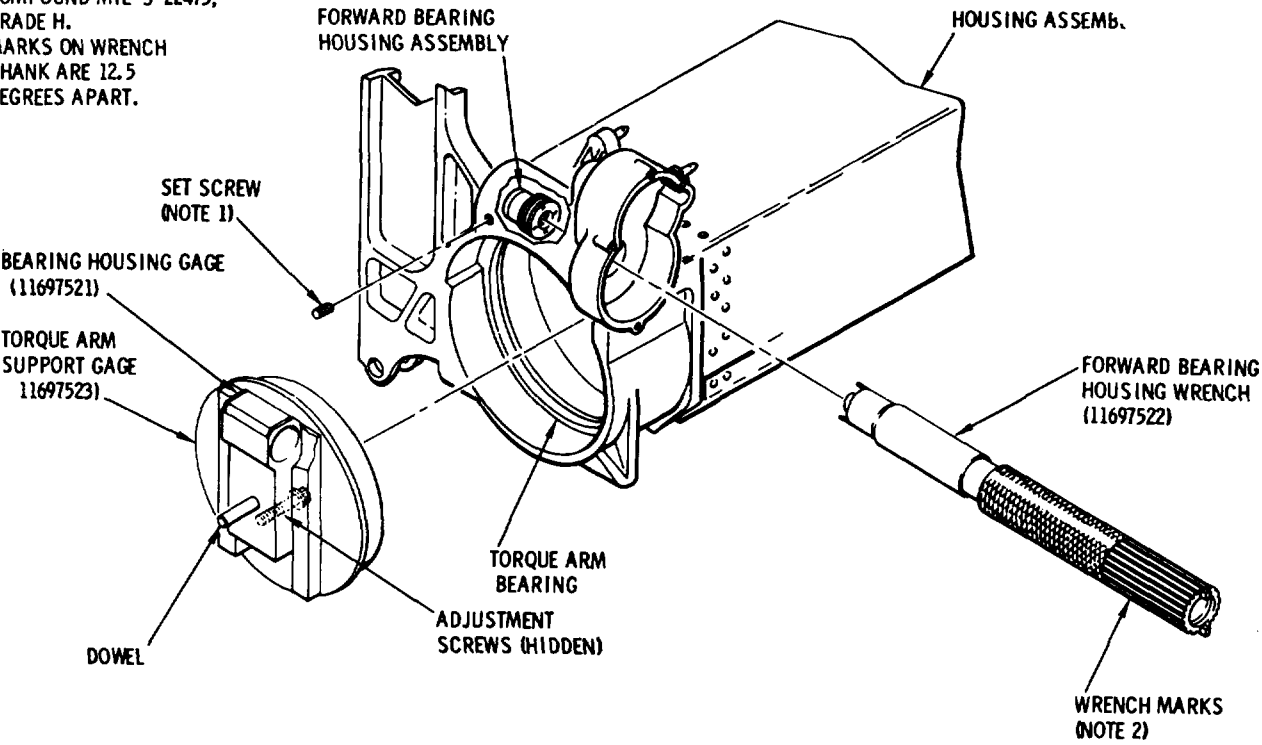

WE15662A

Figure 5-11. Adjustment of forward bearing housing assembly.

CHAPTER 6

REPAIR OF HELICOPTER REFLEX SIGHT XM70E1

6-1. Description

The helicopter reflex sight XM70E1 is a precision optical instrument of light construction for helicopter use. Care should be taken during all maintenance and repair work to avoid subjecting the unit to rough handling that could cause misalignment of components or breakage of optical glass.

6-2. Disassembly/Assembly

Disassemble the helicopter reflex sight XM70E1 as required for replacement of worn or damaged parts in the sequence of item numbers on figures 6-1 through 6-7. Assembly is performed in reverse of the disassembly sequence. Adjustments that are to be accomplished during assembly are outlined in paragraph 6-4.

6-3. Cleaning, Inspection, and Repair

a. Cleaning. Clean external metal surfaces with a cloth moistened with dry cleaning solvent (SD), then dry with a clean dry cloth. Do not use solvent on the beamsplitter or the projector lens. Clean these optical surfaces only with lens tissue.

b. Inspection. Check for damage, distortion, and looseness between fitted components. Check for cracked or broken optical elements.

c. Repair. Repairs are limited to replacement of worn or damaged parts and adjustment of the assembly for proper functioning.

6-4. Assembly Adjustment Requirements

During assembly of the sight, the following adjustments will be made.

a. Assemble projector lenses as shown in figure 6-8. Install and adjust reticle as follows:

(1) Install reticle lens in retainer body so that etched pattern will face the objective lens when retainer body is installed in projector. Install preformed packing, flat washer, and retainer nut in retainer body to form a complete assembly.

(2) Install reticle retainer assembly in projector

housing.

(3) Mount the projector housing in a suitable fixture and illuminate the reticle using an auxiliary light or an unattached lamp housing.

(4) Adjust infinity focus of reticle for zero (0) ± 0.2 diopters using a dioptrimeter, Keuffel and Esser No. 182350 or equivalent.

Note. When reticle is properly focused, the vertical axis of the reticle pattern shall be perpendicular to projector axis A within 0 \pm 30' (zero degrees, 30 minutes). Loosen or remove retainer nut to reposition reticle lens as required. Use care to avoid turning retainer body in projector since focus will be affected.

(5) Apply sealing compound MIL-S-11031B to exposed threads of reticle retainer body to lock it in position and to produce an airtight seal.

b. Install rod assembly and adjust stowed position eccentric pin as shown in figure 6-8.

c. Adjust detent assembly, elevation knob assembly, and other assemblies as shown in figure 6-8

6-5. Sight Assembly Purging

After assembly of the sight and any time the projector housing is opened and optical elements are exposed to air, the projector must be urged with dry nitrogen and resealed. Refer to TM 9-105-298-12 for procedure.

6-6. Final Inspection and Collimation

a. Set-up Instructions. See figure 6-9.

(1) Place elevation and cross leveling fixture "A" on a sturdy work table as to permit the placement of the target assembly "B" for easy viewing.

(2) Set indices at zero (0) elevation and cross leveling fixture "A" to track a plumb line. Place sight adapter "C" on plate "D" of fixture "A". Use a 5-second level to cross level sight adapter "C" before pinning.

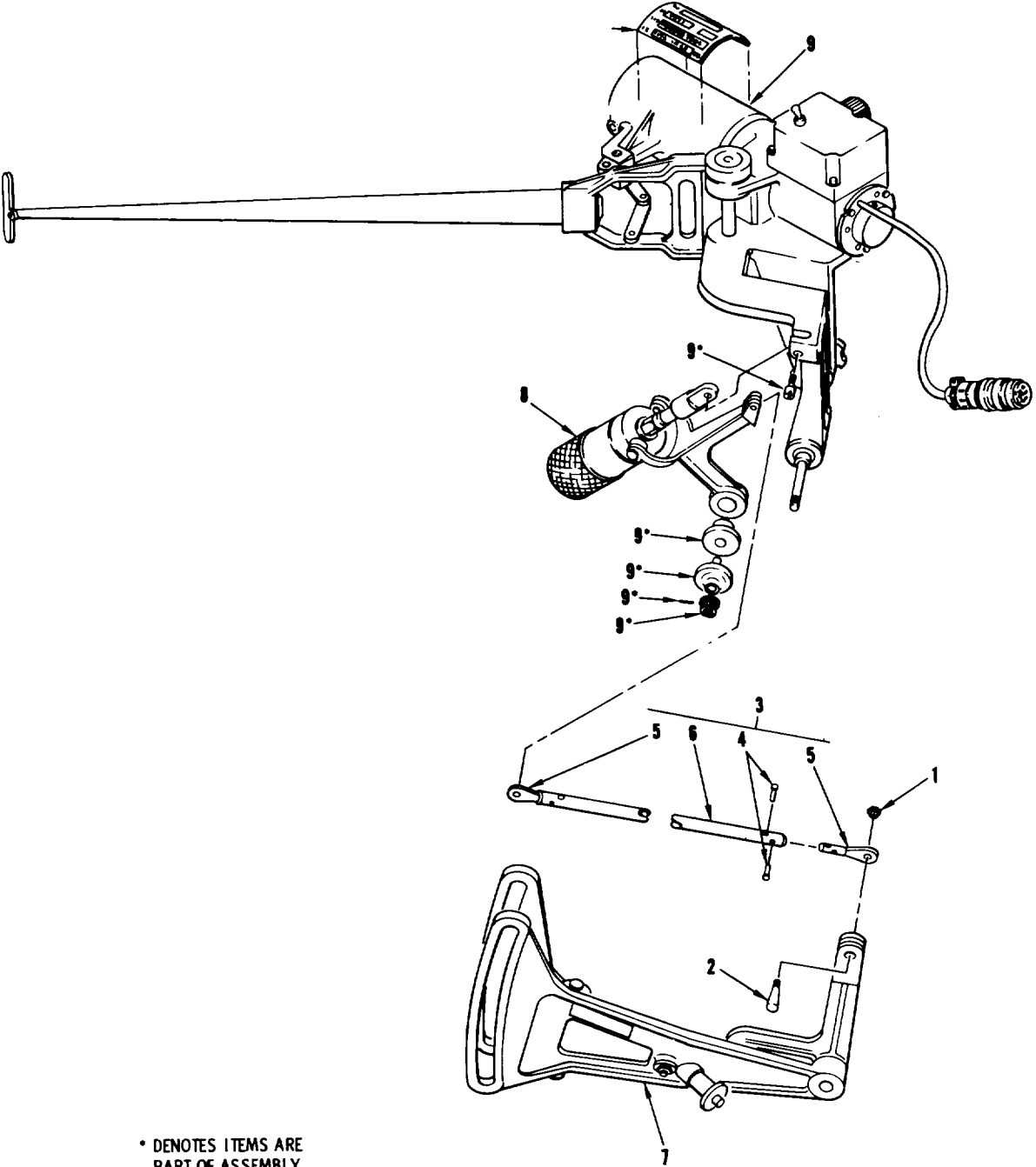

• DENOTES ITEMS ARE PART OF ASSEMBLY REPRESENTED BY NUMBER

WE 15611

Figure 6-1. Helicopter reflex sight XM70E1--partially exploded view.

- 1-Nut
- 2-Pin
- 3-Rod assembly
- 4-Rivet
- 5-Rod end

- 6-Tube
- 7-Support assembly
- 8-Elevation control assembly
- 9-Reticle image projector
- 10-Plate

Figure 6-1--Continued.

(3) Place helicopter reflex sight XM70E1 in position on sight adapter "C" and lock in position by fastener knob "E".

(4) Turn elevation knob "K" until "250" on the white scale is in coincidence with knob housing index mark.

(5) Place beamsplitter arm "M" in the use position. Lock arm "F" by pin "G" at the zero (0) position.

(6) Connect a 24 VDC power supply to connector of the reticle projector, switch projector on and adjust projected image brilliance as required.

(7) The collimator target "H" shall be set so that the horizontal reticle lines are on the same plane as the horizontal projected image. Switch projector off. Plumb collimator target reticle to a plumb line. Viewing thru 3X telescope "J", superimpose telescope reticle on collimator target reticle.

b. Collimation.

(1) Switch projector on and look through 3X telescope "J" to observe projected reticle image and collimator target "H" reticle.

(2) Turn sight azimuth adjustment screw near sight fastener knob "E". Observe that line of sight can be locked at any angle between 2.5 degrees right and 0.5 degree left. Lock adjustment screw at zero angle.

c. Elevation Excursion Range.

(1) From zero (0) line of sight position, turn elevation knob "K" to the extreme range position.

Note. Depress range detent plunger when turning elevation knob into yellow marked range.

(2) Set arm "F" to 30 degrees depressed position and lock with pin "G".

(3) Return to zero (0) line of sight then move arm "F" to 15 degrees elevation position and lock with pin "G".

(4) Return to zero (0) line of sight.

d. Elevation Accuracy

(1) Make angular input changes to check the sight at various points by using arm "F".

(2) After each input change, return the projected reticle image on the beamsplitter back to zero (0) line of sight position using the elevation and cross-leveling

fixture "A" then take a reading.

(3) Angular changes in line of sight between 213 mils depression and 177 mils elevation shall be within 2.0 mils. Angular changes between 213 mils depression and 427 mils depression shall be within 4.0 mils.

e. Plumb Travel

(1) Make angular input changes as described in *c* (1) and *d*. (2) above.

(2) The projected reticle vertical line shall track a plumb line within 2.0 mils from 177 mils elevation to 213 mils depression and within 4.0 mils from 213 mils depression to 426 mils depression.

f. Superelevation Accuracy. Super elevation input changes shall be made using the elevation knob "K" then brought back to zero (0) line of sight using the elevation and cross leveling fixture "A". Superelevation inputs and tolerances are as follows:

Range (Meters)	Sight Change (Mils)	Tolerance (Mils-)
250 (White)		
500 (White)	12.01	1.5
750 (White)	18.24	2.0
1000 (White)	28.08	2.0
250 (Yellow)	-8.55	2.0
500 (Yellow)	34.90	3.0
750 (Yellow)	71.18	3.0
1000 (Yellow)	111.37	3.0
1250 (Yellow)	156.10	3.0
1500 (Yellow)	212.32	2.5

g. Height Adjustment

(1) Place mirror assembly "L" in position shown and clamp to beam-splitter arm "M".

(2) While sighting through 3X telescope "J", adjust the mirror to superimpose the telescope reticle image on its reflected image. Azimuth adjustments are made by loosening two thumb screws "P" and turning the end piece. Elevation adjustments are made using the three set screws at the lower end of the mirror assembly.

(3) Loosen height adjustment knob "R" and slip the sight up and down through its full excursion.

Caution: Ease the sight into position for check. Do not allow it to drop.

(4) The reflected reticle, viewed through 3X

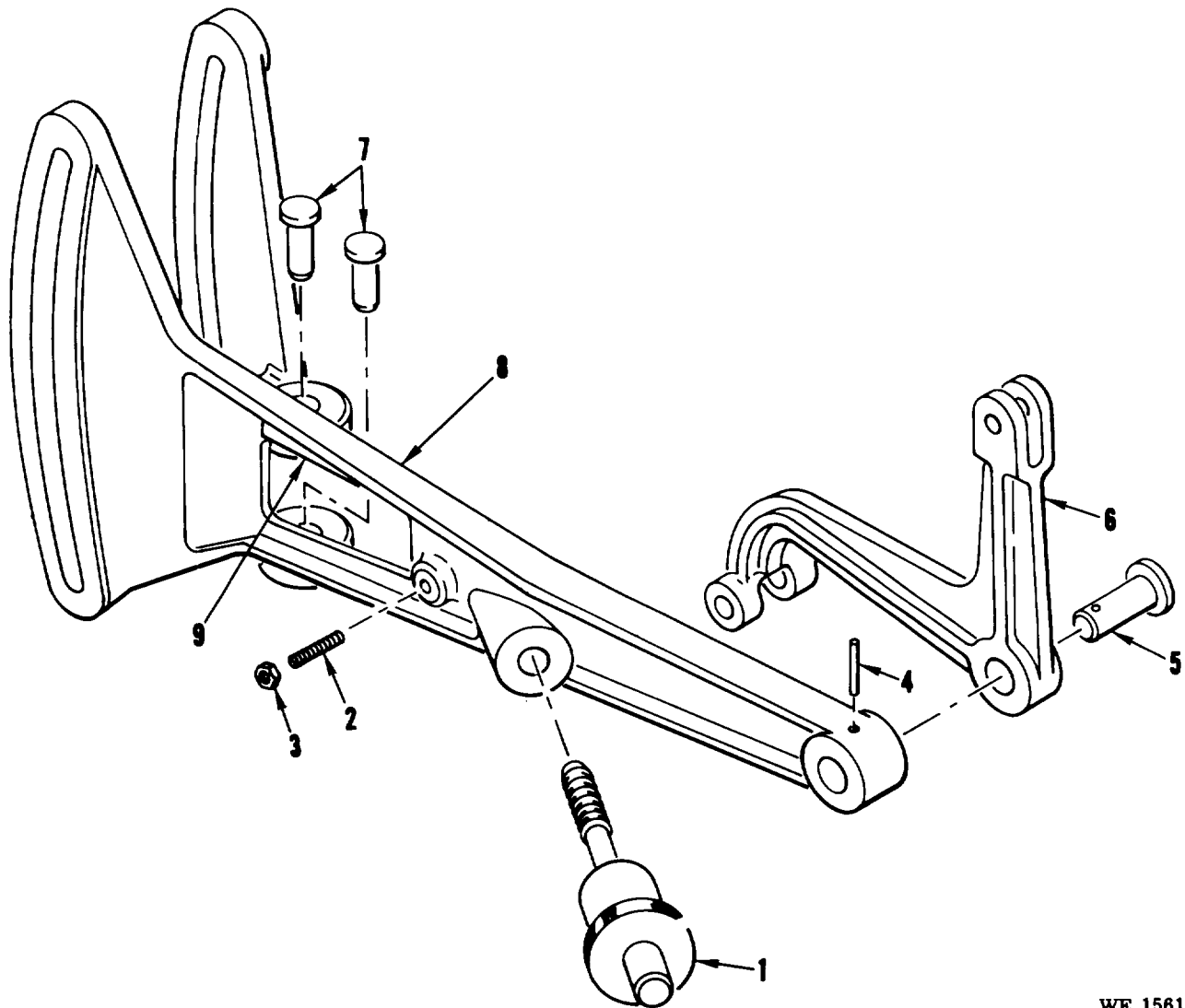

WE 15612

- 1—Pushbutton stud
- 2—Set screw
- 3—Nut
- 4—Spring pin
- 5—Shaft

- 6—Bellcrank
- 7—Pin
- 8—Support
- 9—Decal

Figure 6-2. Support assembly—exploded view.

telescope "J" shall not deviate from the telescope more than 2.0 mils through the full excursion of the sight.

h. Parallax

- (1) Set collimator target "H" at a range between 500 and 1000 meters.
- (2) Switch on sight reticle image projector.
- (3) Remove 3X telescope "J" and place eye 8 to

10 inches from the center of the beamsplitter.

(4) Move head from side to side and up and down. Parallax between projected reticle and optical axis shall not exceed 2.0 mils over full aperture of the beamsplitter.

i. Final Clean-up

- (1) Disconnect 24 VDC power from the sight.
- (2) Remove sight assembly from the test fixture.

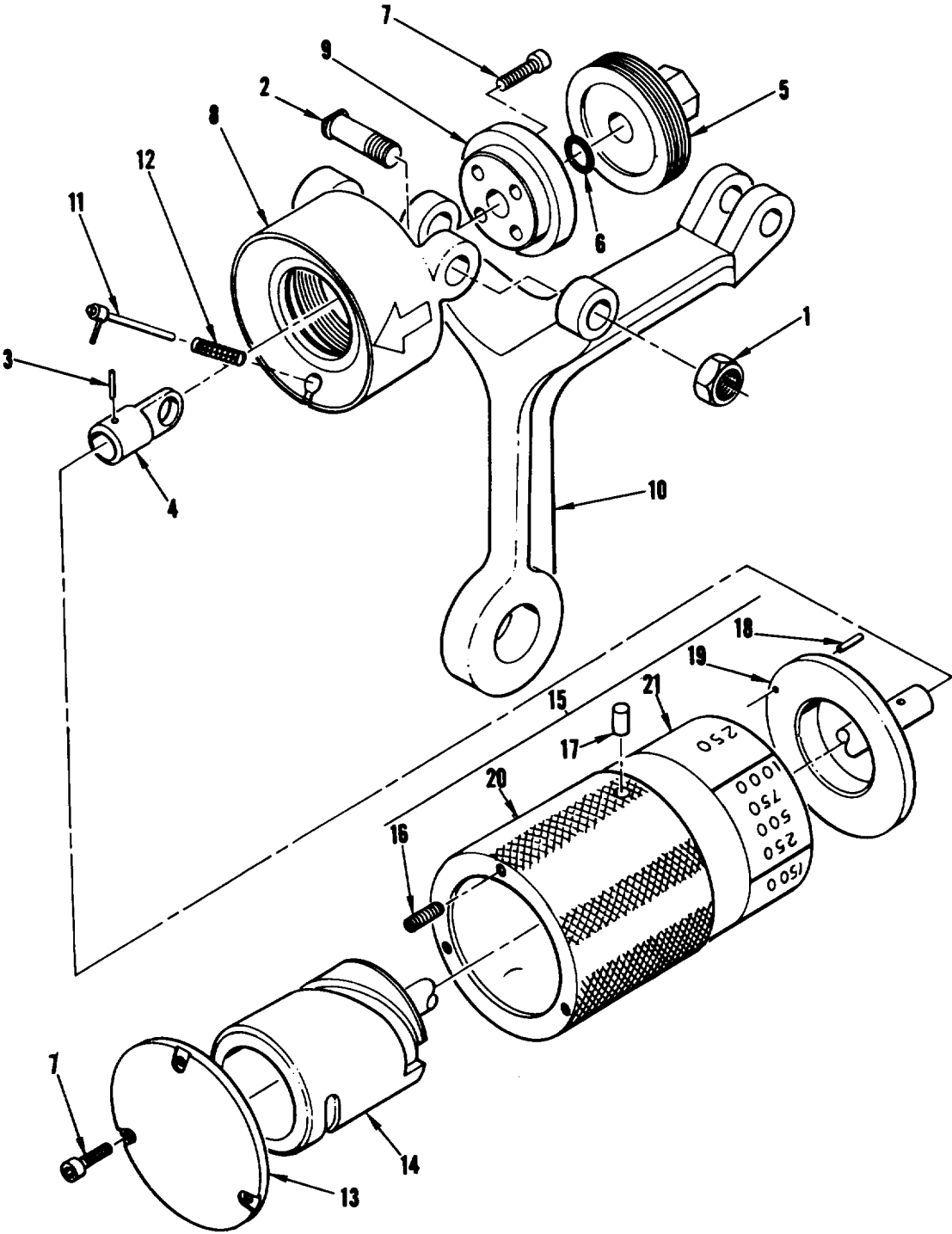

WE 15613A

Figure 6-3. Elevation control assembly—exploded view.

1-Nut
2-Bolt
3-Spring pin
4-Coupling
5-Retainer
6-Packing
7-Screw
8-Housing
9-Bearing
10-Link
11-Plunger

12-Spring
13-Cap
14-Cam
15-Knob assembly
16-Set screw
17-Pin
18-Spring pin
19-Detent
20-Knob
21-Plate

Figure 6-3. -Continued.

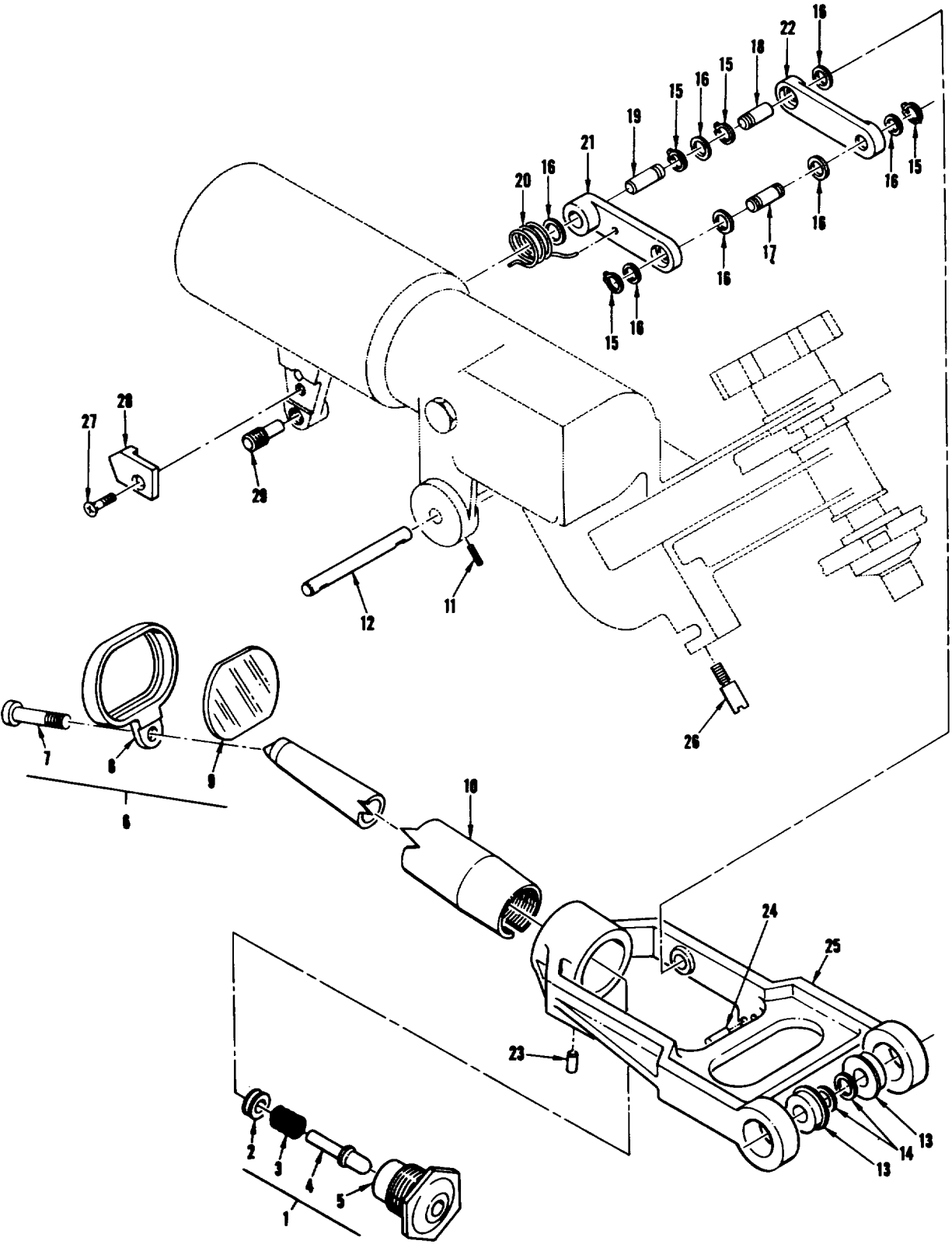

WE 15615

Figure 6-4. Reticle projector assembly—partially exploded view.

- | | |
|--------------------------|------------------|
| 1-Detent assembly | 16-Washer |
| 2-Spring retainer | 17-Shaft |
| 3-Spring | 18-Shaft |
| 4-Plunger | 19-Shaft |
| 5-Body | 20-Spring |
| 6-Beam splitter assembly | 21-Arm |
| 7-Screw | 22-Arm |
| 8-Retainer | 23-Pin |
| 9-Optical glass | 24-Spring pin |
| 10-Arm | 25-Arm |
| 11-Set screw | 26-Screw |
| 12-Shaft | 27-Screw |
| 13-Bearing | 28-Bracket |
| 14-Washer | 29-Eccentric pin |
| 15-Retainer ring | |

Figure 6-4—Continued.

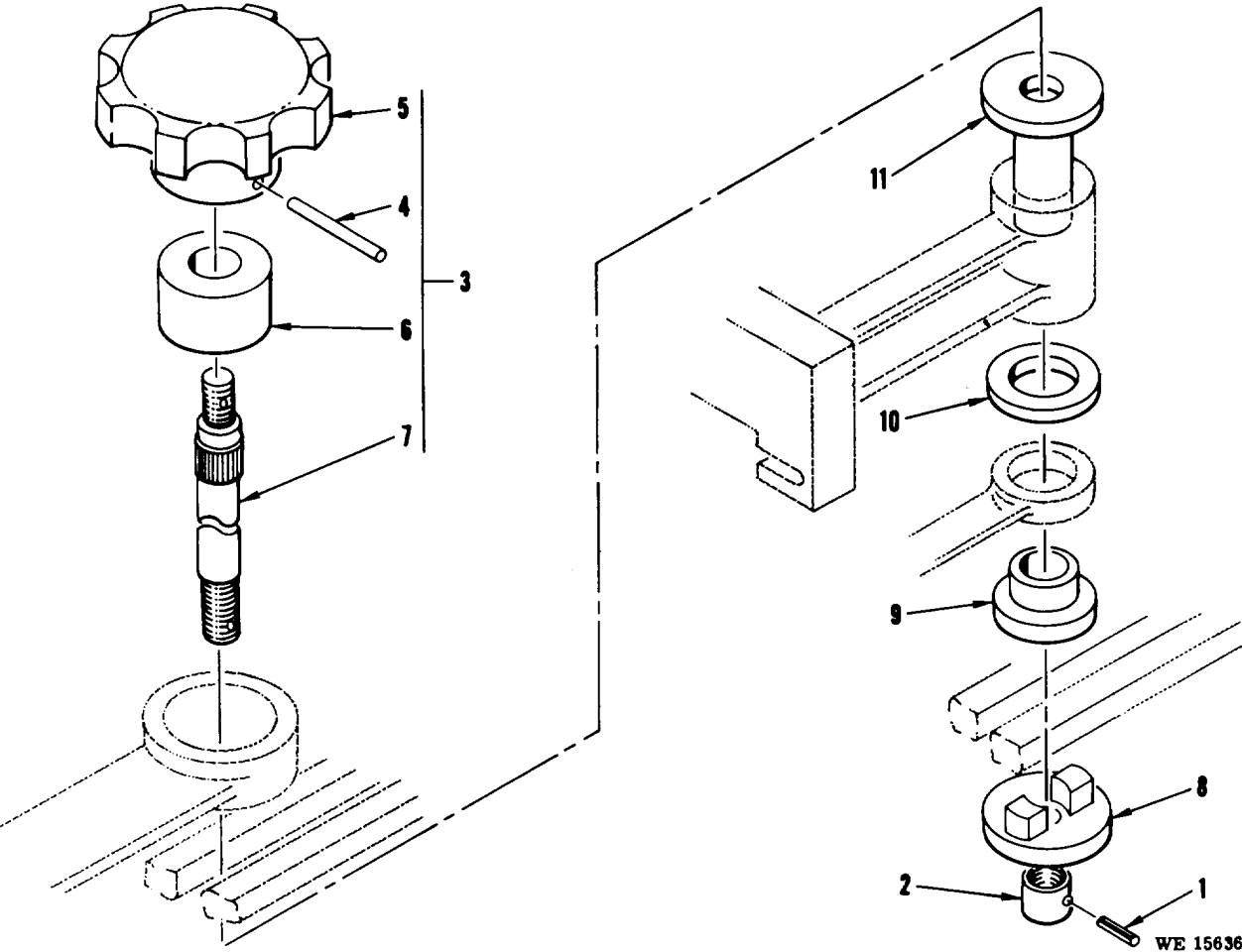

- 1-Spring pin
- 2-Nut
- 3-Knob assembly
- 4-Spring pin
- 5-Knob
- 6-Spacer

- 7-Shaft
- 8-Tab washer
- 9-Bushing
- 10-Washer
- 11-Bushing

Figure 6-5. Height adjustment linkage—exploded view.

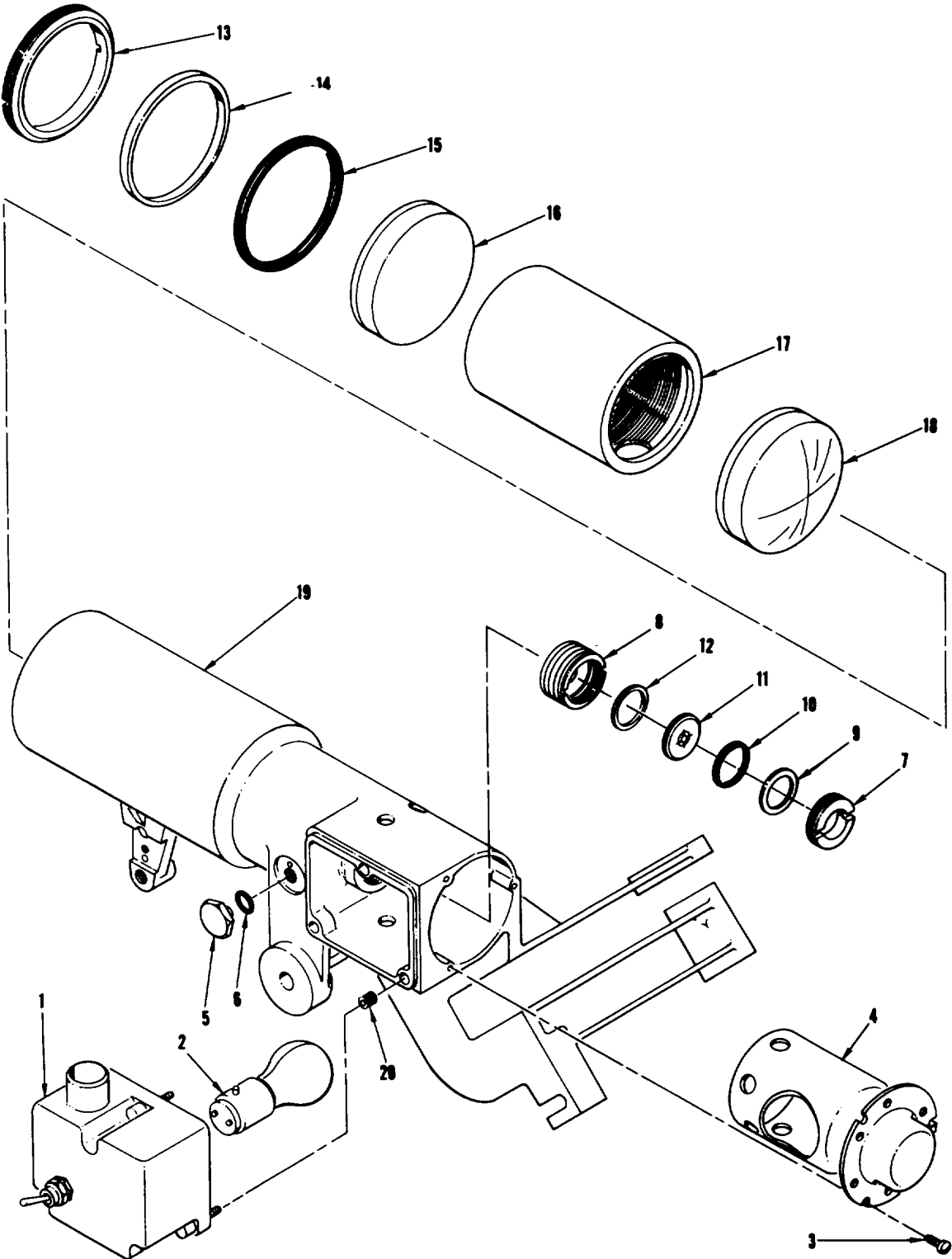

WE 15614A

Figure 6-6. Main projector housing—exploded view.

- 1-Lamp housing assembly
- 2-Lamp
- 3-Screw
- 4-Light shield
- 5-Plug
- 6-Packing
- 7-Retainer
- 8-Nut
- 9-Washer
- 10-Packing

- 11-Reticle
- 12-Nonmetallic washer
- 13-Retainer
- 14-Washer
- 15-Gasket
- 16-Lens
- 17-Spacer
- 18-Lens
- 19-Housing
- 20-Inser

Figure 6-6—Continued.

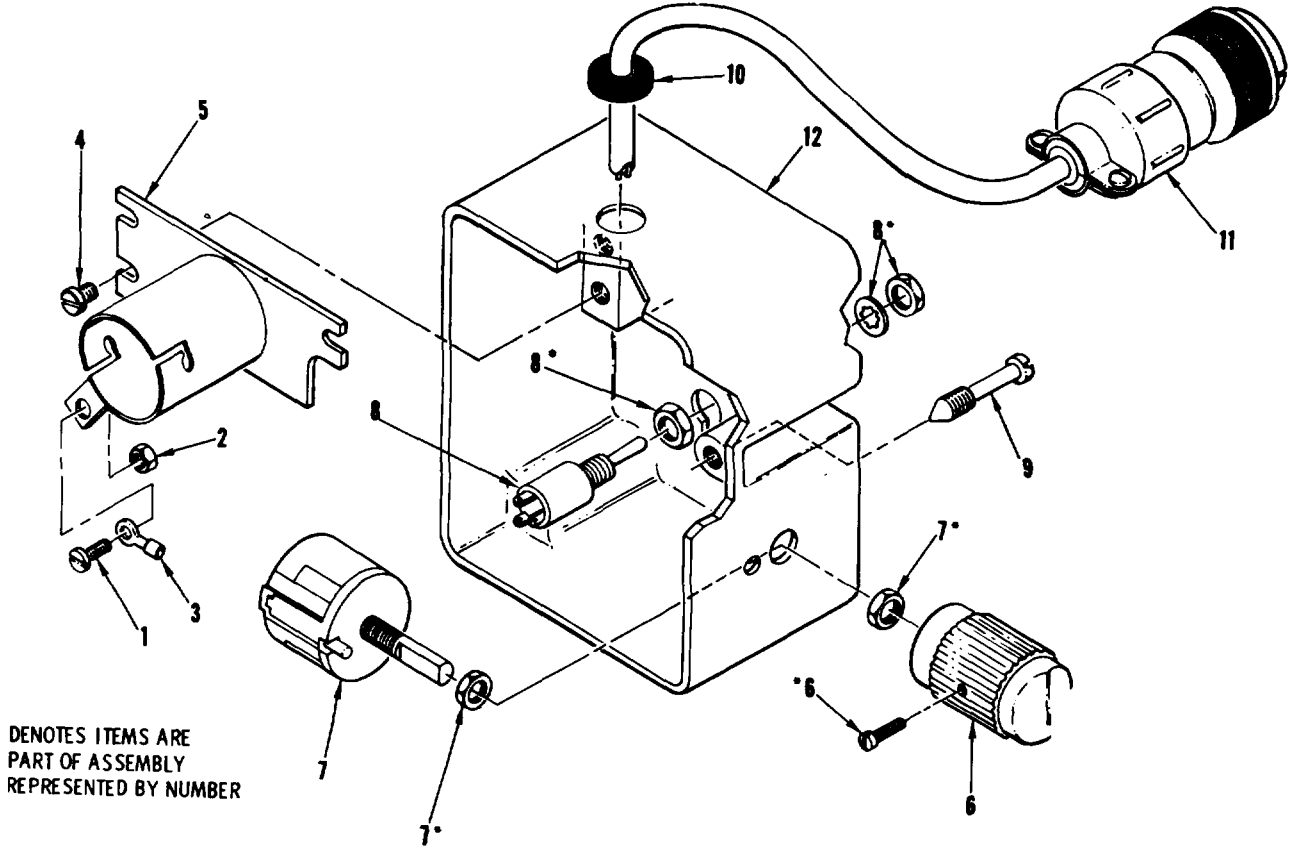

DENOTES ITEMS ARE PART OF ASSEMBLY REPRESENTED BY NUMBER

WE 15617A

- 1-Screw
- 2-Nut
- 3-Terminal
- 4-Screw
- 5-Lamp holder
- 6-Knob

- 7-Rheostat
- 8-Switch
- 9-Screw
- 10-Grommet
- 11-Connector
- 12-Housing

Figure 6-7. Lamp housing assembly—exploded view.

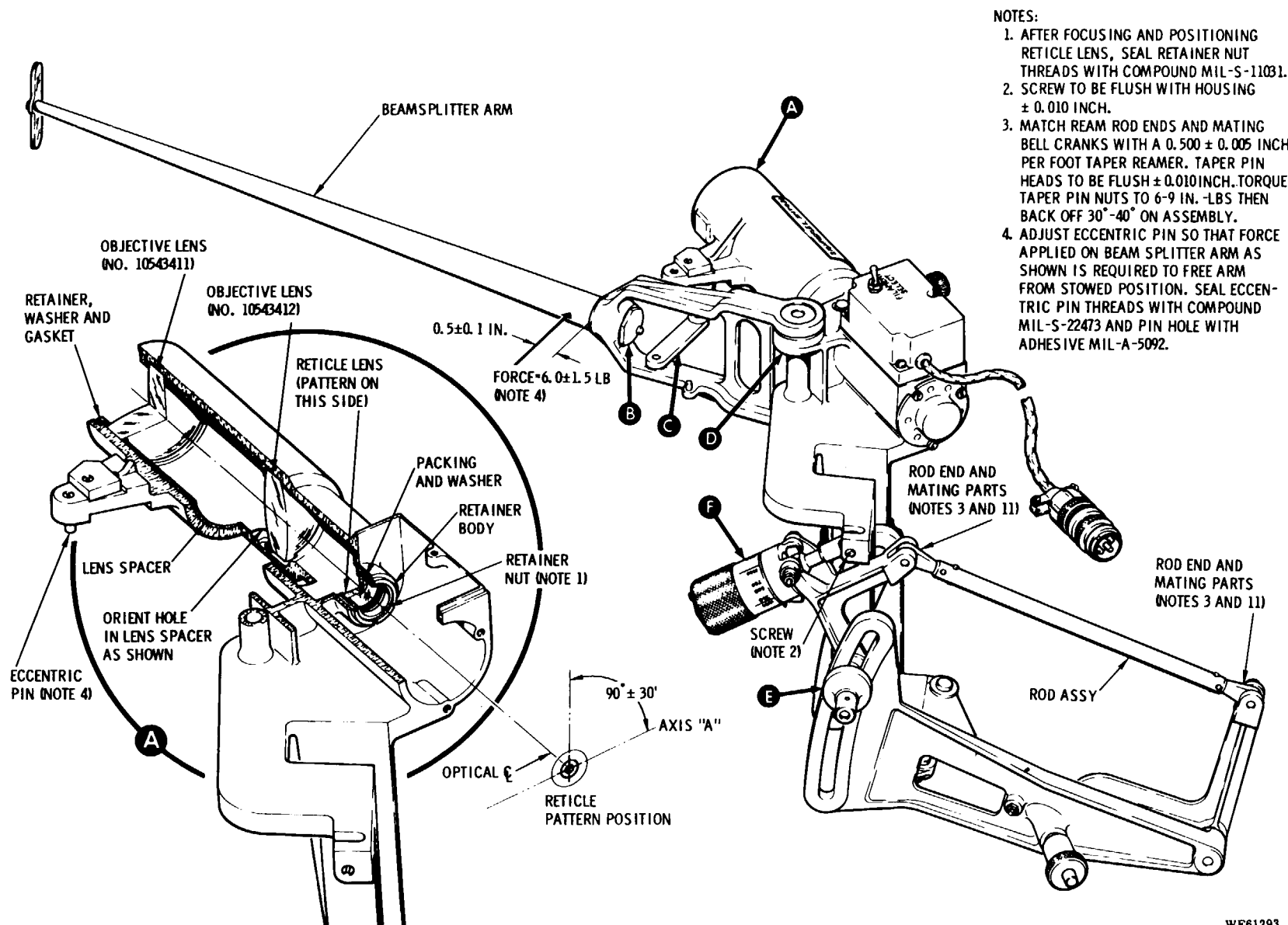

NOTES:

1. AFTER FOCUSING AND POSITIONING RETICLE LENS, SEAL RETAINER NUT THREADS WITH COMPOUND MIL-S-11031.
2. SCREW TO BE FLUSH WITH HOUSING ± 0.010 INCH.
3. MATCH REAM ROD ENDS AND MATING BELL CRANKS WITH A 0.500 ± 0.005 INCH PER FOOT TAPER REAMER. TAPER PIN HEADS TO BE FLUSH ± 0.010 INCH. TORQUE TAPER PIN NUTS TO 6-9 IN. -LBS THEN BACK OFF 30°-40° ON ASSEMBLY.
4. ADJUST ECCENTRIC PIN SO THAT FORCE APPLIED ON BEAM SPLITTER ARM AS SHOWN IS REQUIRED TO FREE ARM FROM STOWED POSITION. SEAL ECCENTRIC PIN THREADS WITH COMPOUND MIL-S-22473 AND PIN HOLE WITH ADHESIVE MIL-A-5092.

Figure 6-8 (1). Sight assembly adjustments (sheet 1 of 2).

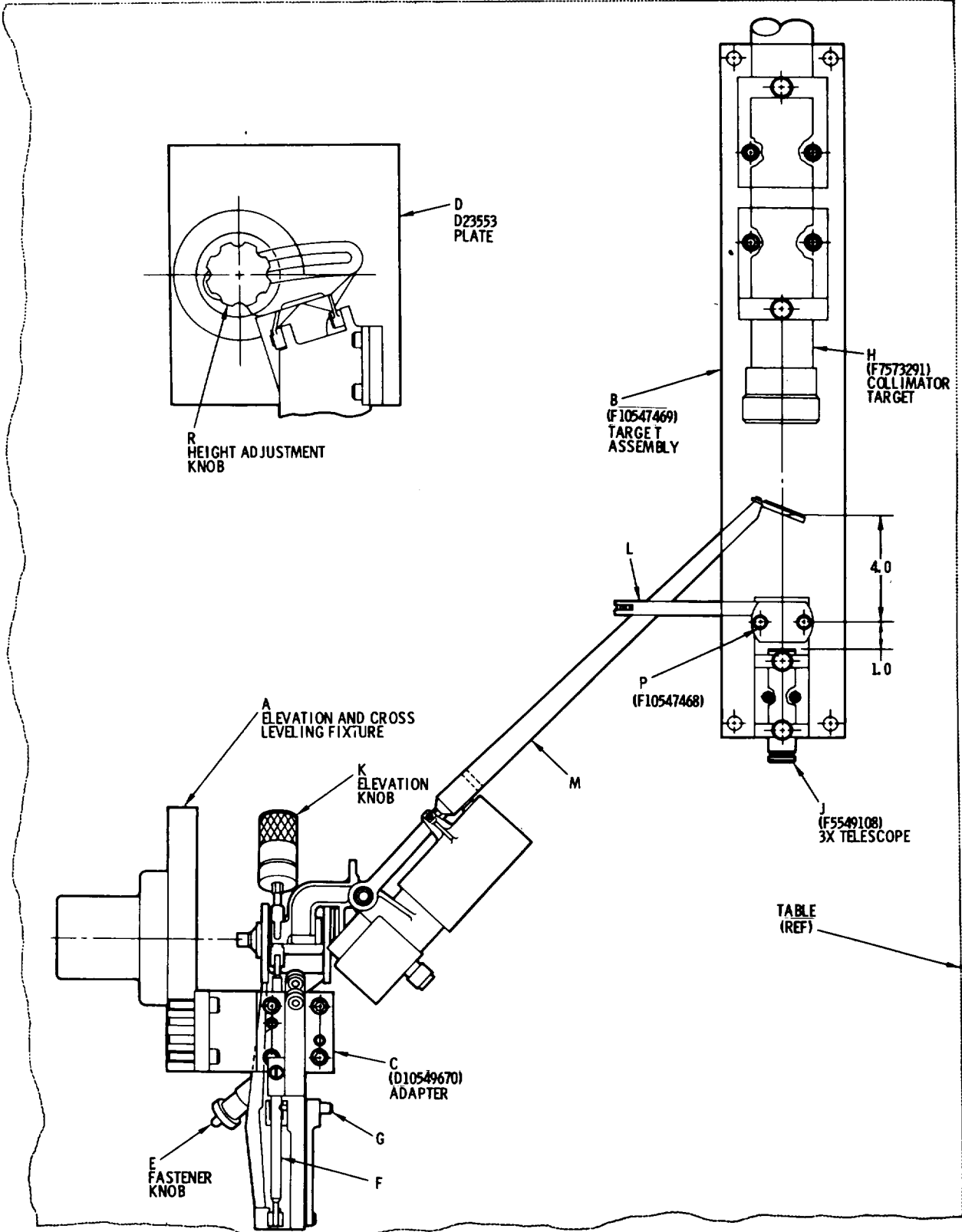

WE 15654A

Figure 6-9. Sight assembly test set up.

A-Elevation and cross leveling fixture
B-Target assembly
C-Sight adapter
D-Plate (part of fixture A)
E-Sight pin
F-Arm
G-Pin
H-Collimator target

J-3X telescope
K-Elevation knob
L-Mirror assembly
M-Beamsplitter arm
P-Thumb screws
R-Knob
S-Surface
T-Support bracket

Figure 6-9—Continued.

CHAPTER 7

FINAL INSPECTION

7-1. General

Each component is inspected during repair as specified in the chapter devoted to that component. Additional inspection of the complete system should be performed as follows:

a. Check the subsystem in accordance with preventive maintenance tables in TM 9-1005-298-12.

b. Lubricate the subsystem in accordance with lubrication chart LO 9-1005-298-12.

c. If the subsystem can be installed on an aircraft, perform operational checks in accordance with

procedures in TM 9-1005-298-12.

d. Check that identification markings correspond with those entered in equipment log (TM 38-750).

e. Check that paint and decals meet standards prescribed in TM 9-213.

f. After compliance with the instructions in this publication the armament subsystem will have been restored to a completely serviceable condition for "RETURN TO USER" or for "RETURN TO STOCK" tagging as appropriate.

APPENDIX A

REFERENCES

1. Publication Indexes

Consult each new issue of the following for the latest changes or revisions to publications listed in this appendix or for new publications on the materiel covered in this manual.

Index of Administrative Publications -----	DA Pam 310-1
Index of Blank Forms -----	DA Pam 310-2
Index of Doctrinal, Training, and Organizational Publications-----	DA Pam 310-
Index of Supply Catalogs and Supply Manuals (Excluding types 7, 8, and 9) -----	DA Pam 31
Index of Technical Manuals, Technical Bulletins, Supply Manuals (types 7, 8, and 9), Supply Bulletins, and Lubrication Orders-----	DA Pam 10-4

2. Forms

In addition to the forms required by the Department of the Army Equipment Record System (TM B8-750), the following forms pertain to this materiel:

Materiel Inspection Tag -----	DA Form 9-1
Recommended Changes to DA Publications -----	DA Form 202
Report of Packaging and Handling Deficiencies -----	DD Form 6
Request for Issue or Turn-In -----	DA Form 2765 and DA Form 2765-1
Requirements for Army Aviation Publications-----	DA Form 12-31
Requisition for Initial Distribution of Publications and Blank Forms-----	DA Form 12-1
Requisition for Publications and Blank Forms -----	DA Form 17

3. Other Publications

The following publications contain information pertinent to this materiel and associated equipment.

a. Ammunition

Ammunition and Explosives-----	SC-1340-9-IL
Ammunition, General -----	TM 9-1900
Ammunition Service in the Theater of Operations -----	FM 9-
Care, Handling, Preservation, and Destruction of Ammunition-----	TM 9-1300-206
Distribution of Ammunition for Training-----	AR 710-1300-1
Malfunctions Involving Ammunition and Explosives (reports control symbol AMC-132) -----	AR 700-1300
Regulations for Firing Ammunitions for Training, Target Practice, and Combat (AFR 50-13)-----	AR 38543

b. Camouflage

Camouflage, Basic Principles and Field Camouflage-----	FM 520
--	--------

c. Decontamination

Chemical, Biological, and Radiological (CBR) Decontamination-----	TM 3-220
Chemical, Biological, and Nuclear Defense -----	FM 21-40

d. Destruction to Prevent Enemy Use

Explosives and Demolitions-----FM 5-25

e. General

Accident Reporting and Records-----AR 385-40

Procedures-----TM 38-750

Basic Cold Weather Manual-----FM 31-70

f. Maintenance and Repair

Cleaning of Ordnance Materiel-----TM 9-208-1

Command Maintenance Management Inspections-----AR 750-8

Direct Support General Support and Depot Maintenance Repair Parts
and Special Tools List, Armament Subsystem, Helicopter, 7.62 Milli-
meter Machine Gun: High Rate, XM27E1-----TM 9-1005-298-35P

General Maintenance Procedures for Fire Control Materiel-----TM 9-254

Inspection, Care and Maintenance of Antifriction Bearings-----TM 9-214

Lubrication of Ordnance Materiel-----TM 9-273

Lubrication Order, Armament Subsystem, Helicopter, 7.62 Millimeter
Machine Gun: High Rate, XM27E1-----LO 9-1005-298-12

Materials Used for Cleaning, Preserving, Abrading, and Cementing
Ordnance Materiel and Related Materials Including Chemicals-----TM 9-247

Operator and Organizational Maintenance Manual, Armament Subsys-
tem, Helicopter, 7.62 Millimeter Machine Gun: High Rate, XM27E1-----TM 9-1005-298-12

Operator's Manual, Welding Theory and Application-----TM 9-237

Organizational, Policies, and Responsibilities for Maintenance Operation-----AR 750-5

Painting Instructions for Field Use-----TM 9-213

System for Painting and Finishing Fire Control Materiel-----MIL-STD 194A

Adhesive, Rubber Base, General Purpose-----MIL-A-5902B and

Adhesive-Sealant, Silicone, RTV, General-Purpose for Electrical and
Mechanical Sealing-----MIL-A-46106

Sealing Compound, Adhesive, Curing Polysulfide Base-----MIL-S-11031B

Sealing, Locking and Retaining Compounds, Single Component-----MIL-S-22473C GR31
and MIL-S-22473C GR20

Elementary Optics and Application to Fire Control Instruments-----TM 9-258

g. Operations

Operation and Maintenance of Army Materiel in Extreme Cold Weather
0° to -65°F (TO 36-1-40)-----TM 9-207

h. Shipment and Storage

DSU/Installation Stock Control and Supply Procedures (Army Field
Stock Control Procedures)-----AR 711-16

Preservation, Packaging, and Packing-----AR 700-15

Requisitioning, Receipt, and Issue System-----AR 725-50

Standards for Overseas Shipment or Domestic Issue of Small Arms,
Aircraft Armament, Towed Howitzers, Mortars, Recoilless Rifles,
Rocket Launchers, and Associated Fire Control Equipment-----TB 9-1000-247-35

Storage and Materiel Handling-----TM 743-200-1

By Order of the Secretary of the Army:

Official:

KENNETH G. WICKHAM,
*Major General, United States Army,
The Adjutant General.*

W. C. WESTMORELAND,
*General, United States Army,
Chief of Staff.*

Distribution:

To be distributed in accordance with DA Form 1231, (qty rqr block no. 129) Direct and General Support maintenance requirements for subsystem XM27F1.

☆U.S. GOVERNMENT PRINTING OFFICE : 1990 O - 262-912 (30241)

RECOMMENDED CHANGES TO EQUIPMENT TECHNICAL PUBLICATIONS



THEN... JOT DOWN THE DOPE ABOUT IT ON THIS FORM, CAREFULLY TEAR IT OUT, FOLD IT AND DROP IT IN THE MAIL!

SOMETHING WRONG WITH THIS PUBLICATION?

FROM: (PRINT YOUR UNIT'S COMPLETE ADDRESS)

DATE SENT

PUBLICATION NUMBER

PUBLICATION DATE

PUBLICATION TITLE

BE EXACT... PIN-POINT WHERE IT IS

IN THIS SPACE TELL WHAT IS WRONG AND WHAT SHOULD BE DONE ABOUT IT:

PAGE NO.

PARA-GRAPH

FIGURE NO.

TABLE NO.

TEAR ALONG PERFORATED LINE

PRINTED NAME, GRADE OR TITLE, AND TELEPHONE NUMBER

SIGN HERE:

DA FORM 2028-2
1 JUL 79

PREVIOUS EDITIONS ARE OBSOLETE.

P.S.—IF YOUR OUTFIT WANTS TO KNOW ABOUT YOUR RECOMMENDATION MAKE A CARBON COPY OF THIS AND GIVE IT TO YOUR HEADQUARTERS.

PIN: 026420-000